

# GCSE (9-1) Mathematics

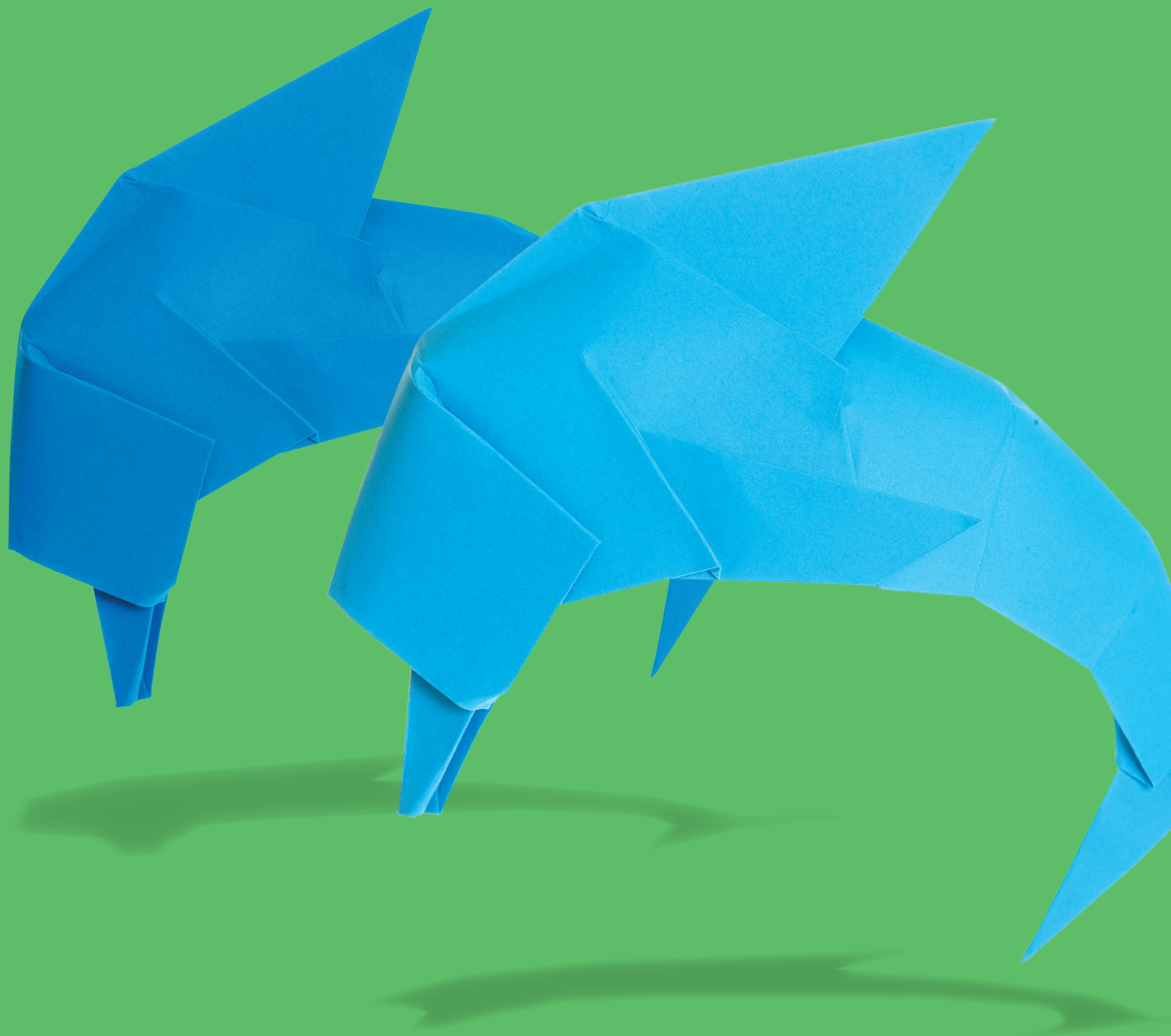

## Sample Assessment Materials

---

Pearson Edexcel Level 1/Level 2 GCSE (9-1) in Mathematics (1MA1)

---

*First teaching from September 2015*

---

*First certification from June 2017*

Issue 2

**Edexcel, BTEC and LCCI qualifications**

Edexcel, BTEC and LCCI qualifications are awarded by Pearson, the UK's largest awarding body offering academic and vocational qualifications that are globally recognised and benchmarked. For further information, please visit our qualification websites at [www.edexcel.com](http://www.edexcel.com), [www.btec.co.uk](http://www.btec.co.uk) or [www.lcci.org.uk](http://www.lcci.org.uk). Alternatively, you can get in touch with us using the details on our contact us page at [qualifications.pearson.com/contactus](http://qualifications.pearson.com/contactus)

**About Pearson**

Pearson is the world's leading learning company, with 40,000 employees in more than 70 countries working to help people of all ages to make measurable progress in their lives through learning. We put the learner at the centre of everything we do, because wherever learning flourishes, so do people. Find out more about how we can help you and your learners at [qualifications.pearson.com](http://qualifications.pearson.com)

*References to third party material made in this document are made in good faith. Pearson does not endorse, approve or accept responsibility for the content of materials, which may be subject to change, or any opinions expressed therein. (Material may include textbooks, journals, magazines and other publications and websites.)*

*All information in this document is correct at time of publication.*

Original origami artwork: Mark Bolitho  
Origami photography: Pearson Education Ltd/Naki Kouyioumtzis

ISBN 9781446927212

All the material in this publication is copyright  
© Pearson Education Limited 2015

# Contents

<b>1</b>	<b>Introduction</b>	<b>1</b>
<b>2</b>	<b>General marking guidance</b>	<b>3</b>
<b>3</b>	<b>Mathematics Paper 1F</b>	<b>7</b>
<b>4</b>	<b>Mathematics Paper 1F Mark Scheme</b>	<b>27</b>
<b>5</b>	<b>Mathematics Paper 2F</b>	<b>35</b>
<b>6</b>	<b>Mathematics Paper 2F Mark Scheme</b>	<b>55</b>
<b>3</b>	<b>Mathematics Paper 3F</b>	<b>63</b>
<b>4</b>	<b>Mathematics Paper 3F Mark Scheme</b>	<b>83</b>
<b>3</b>	<b>Mathematics Paper 1H</b>	<b>89</b>
<b>4</b>	<b>Mathematics Paper 1H Mark Scheme</b>	<b>109</b>
<b>5</b>	<b>Mathematics Paper 2H</b>	<b>117</b>
<b>6</b>	<b>Mathematics Paper 2H Mark Scheme</b>	<b>137</b>
<b>3</b>	<b>Mathematics Paper 3H</b>	<b>145</b>
<b>4</b>	<b>Mathematics Paper 3H Mark Scheme</b>	<b>165</b>



# Introduction

---

The Pearson Edexcel Level 1/Level 2 GCSE (9-1) in Mathematics is designed for use in schools and colleges. It is part of a suite of GCSE qualifications offered by Pearson.

These sample assessment materials have been developed to support this qualification and will be used as the benchmark to develop the assessment students will take.



# General marking guidance

---

These notes offer general guidance, but the specific notes for examiners appertaining to individual questions take precedence.

- 1** All candidates must receive the same treatment. Examiners must mark the last candidate in exactly the same way as they mark the first.

Where some judgement is required, mark schemes will provide the principles by which marks will be awarded; exemplification/indicative content will not be exhaustive.

- 2** All the marks on the mark scheme are designed to be awarded; mark schemes should be applied positively. Examiners should also be prepared to award zero marks if the candidate's response is not worthy of credit according to the mark scheme. If there is a wrong answer (or no answer) indicated on the answer line always check the working in the body of the script (and on any diagrams), and award any marks appropriate from the mark scheme.

**Questions where working is not required:** In general, the correct answer should be given full marks.

**Questions that specifically require working:** In general, candidates who do not show working on this type of question will get no marks – full details will be given in the mark scheme for each individual question.

- 3** **Crossed out work**

This should be marked **unless** the candidate has replaced it with an alternative response.

- 4** **Choice of method**

If there is a choice of methods shown, mark the method that leads to the answer given on the answer line.

If no answer appears on the answer line, mark both methods **then award the lower number of marks.**

- 5** **Incorrect method**

If it is clear from the working that the "correct" answer has been obtained from incorrect working, award 0 marks. Send the response to review for your Team Leader to check.

- 6** **Follow through marks**

Follow through marks which involve a single stage calculation can be awarded without working as you can check the answer, but if ambiguous do not award.

Follow through marks which involve more than one stage of calculation can only be awarded on sight of the relevant working, even if it appears obvious that there is only one way you could get the answer given.

## **7 Ignoring subsequent work**

It is appropriate to ignore subsequent work when the additional work does not change the answer in a way that is inappropriate for the question or its context. (eg. an incorrectly cancelled fraction when the unsimplified fraction would gain full marks).

It is not appropriate to ignore subsequent work when the additional work essentially makes the answer incorrect (eg. incorrect algebraic simplification).

## **8 Probability**

Probability answers must be given as a fraction, percentage or decimal. If a candidate gives a decimal equivalent to a probability, this should be written to at least 2 decimal places (unless tenths).

Incorrect notation should lose the accuracy marks, but be awarded any implied method marks.

If a probability answer is given on the answer line using both incorrect and correct notation, award the marks.

If a probability fraction is given then cancelled incorrectly, ignore the incorrectly cancelled answer.

## **9 Linear equations**

Unless indicated otherwise in the mark scheme, full marks can be gained if the solution alone is given on the answer line, or otherwise unambiguously identified in working (without contradiction elsewhere). Where the correct solution only is shown substituted, but not identified as the solution, the accuracy mark is lost but any method marks can be awarded (embedded answers).

## **10 Range of answers**

Unless otherwise stated, when an answer is given as a range (e.g 3.5 – 4.2) then this is inclusive of the end points (e.g 3.5, 4.2) and all numbers within the range.



### Guidance on the use of abbreviations within this mark scheme

<b>M</b>	method mark awarded for a correct method or partial method
<b>P</b>	process mark awarded for a correct process as part of a problem solving question
<b>A</b>	accuracy mark (awarded after a correct method or process; if no method or process is seen then full marks for the question are implied but see individual mark schemes for more details)
<b>C</b>	communication mark
<b>B</b>	unconditional accuracy mark (no method needed)
<b>oe</b>	or equivalent
<b>cao</b>	correct answer only
<b>ft</b>	follow through (when appropriate as per mark scheme)
<b>sc</b>	special case
<b>dep</b>	dependent (on a previous mark)
<b>indep</b>	independent
<b>awrt</b>	answer which rounds to
<b>isw</b>	ignore subsequent working



Write your name here

Surname

Other names

**Pearson Edexcel**  
**Level 1/Level 2 GCSE (9 - 1)**

Centre Number

--	--	--	--	--

Candidate Number

--	--	--	--	--

# Mathematics

## Paper 1 (Non-Calculator)

**Foundation Tier**

Sample Assessment Materials – Issue 2

**Time: 1 hour 30 minutes**

Paper Reference

**1MA1/1F**

**You must have:** Ruler graduated in centimetres and millimetres, protractor, pair of compasses, pen, HB pencil, eraser.

Total Marks



### Instructions

- Use **black** ink or ball-point pen.
- **Fill in the boxes** at the top of this page with your name, centre number and candidate number.
- Answer **all** questions.
- Answer the questions in the spaces provided – *there may be more space than you need.*
- **Calculators may not be used.**
- Diagrams are **NOT** accurately drawn, unless otherwise indicated.
- You must **show all your working out.**

### Information

- The total mark for this paper is 80
- The marks for **each** question are shown in brackets – *use this as a guide as to how much time to spend on each question.*

### Advice

- Read each question carefully before you start to answer it.
- Keep an eye on the time.
- Try to answer every question.
- Check your answers if you have time at the end.

S48571A

©2015 Pearson Education Ltd.

6/4/7/7/7/4/6/6/6/6/



Turn over ►

**PEARSON**

**Answer ALL questions.**

**Write your answers in the spaces provided.**

**You must write down all the stages in your working.**

- 1** Write the following numbers in order of size.  
Start with the smallest number.

0.61            0.1            0.16            0.106

.....  
**(Total for Question 1 is 1 mark)**

- 2** Write 0.037 as a fraction.

.....  
**(Total for Question 2 is 1 mark)**

- 3** Write down the 20th odd number.

.....  
**(Total for Question 3 is 1 mark)**

DO NOT WRITE IN THIS AREA

DO NOT WRITE IN THIS AREA

DO NOT WRITE IN THIS AREA

4 Write down all the factors of 20

(Total for Question 4 is 2 marks)

5 Tanya needs to buy chocolate bars for all the children in Year 7  
Each of the 130 children get one chocolate bar.

There are 8 chocolate bars in each packet.

Work out the least number of packets of chocolate bars that Tanya needs to buy.

(Total for Question 5 is 3 marks)

6 Greg rolls a fair ordinary dice once.

(i) On the probability scale, mark with a cross (×) the probability that the dice will land on an odd number.

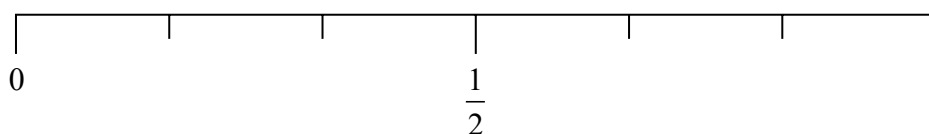

(ii) On the probability scale, mark with a cross (×) the probability that the dice will land on a number less than 5

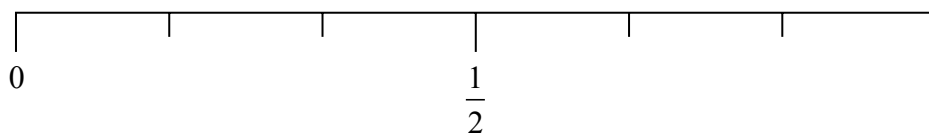

(Total for Question 6 is 2 marks)

- 7 One day Sally earned £60  
She worked for 8 hours.

Work out Sally's hourly rate of pay.

£.....

**(Total for Question 7 is 2 marks)**

- 8 Work out 15% of 80

.....

**(Total for Question 8 is 2 marks)**

- 9 There are 3 red beads and 1 blue bead in a jar.  
A bead is taken at random from the jar.

What is the probability that the bead is blue?

.....

**(Total for Question 9 is 1 mark)**

- 10 There are only black pens and green pens in a box.  
The ratio of the number of black pens in the box to the number of green pens in the box  
is 2 : 5

What fraction of the pens are black?

.....

**(Total for Question 10 is 1 mark)**

DO NOT WRITE IN THIS AREA

DO NOT WRITE IN THIS AREA

DO NOT WRITE IN THIS AREA

DO NOT WRITE IN THIS AREA

DO NOT WRITE IN THIS AREA

DO NOT WRITE IN THIS AREA

- 11** Sally has three tiles.  
Each tile has a different number on it.  
Sally puts the three tiles down to make a number.  
Each number is made with all three tiles.

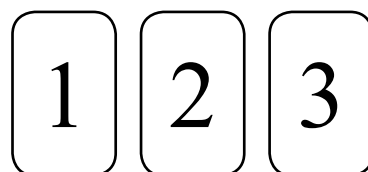

How many different numbers can Sally make?

**(Total for Question 11 is 2 marks)**

12 Here are the first three patterns in a sequence.  
The patterns are made from triangles and rectangles.

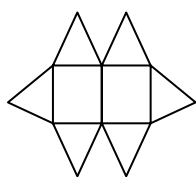

pattern number 1

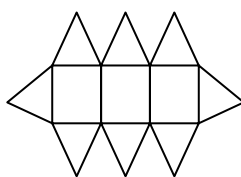

pattern number 2

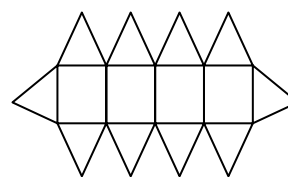

pattern number 3

(a) How many triangles are there in pattern number 7?

.....  
(2)

Charlie says

“There are 4 rectangles in pattern number 3 so there will be 8 rectangles in pattern number 6”

(b) Is Charlie right?

Give a reason for your answer.

.....  
(1)

**(Total for Question 12 is 3 marks)**



DO NOT WRITE IN THIS AREA

DO NOT WRITE IN THIS AREA

DO NOT WRITE IN THIS AREA

13 Paul organised an event for a charity.

Each ticket for the event cost £19.95  
Paul sold 395 tickets.

Paul paid costs of £6000  
He gave all money left to the charity.

(a) Work out an estimate for the amount of money Paul gave to the charity.

£ .....  
(3)

(b) Is your answer to (a) an underestimate or an overestimate?  
Give a reason for your answer.

.....  
.....  
(1)



**(Total for Question 13 is 4 marks)**

14 The table shows information about the numbers of fruit trees in an orchard.

Apple tree	Pear tree	Plum tree
45	20	25

(a) The pictogram shows this information.

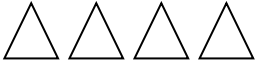
Complete the key for the pictogram.

Apple tree	
Pear tree	
Plum tree	

Key:  represents ..... trees

(1)

(b) There are 90 fruit trees in the orchard.

Apple tree	Pear tree	Plum tree
45	20	25

Draw an accurate pie chart for this information.

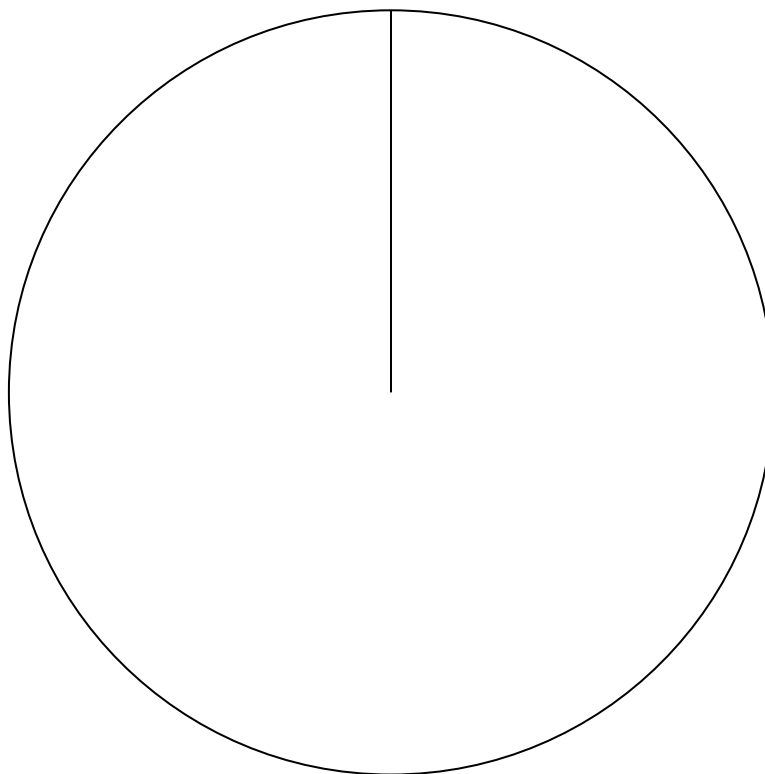

(3)

(Total for Question 14 is 4 marks)

DO NOT WRITE IN THIS AREA

DO NOT WRITE IN THIS AREA

DO NOT WRITE IN THIS AREA

**15** Carpet tiles are going to be used to cover a floor.

The floor is a 1200mm by 1000mm rectangle.  
Each carpet tile is a 40 cm by 30cm rectangle.

Exactly 10 carpet tiles can be used to cover the floor completely.

Show in a labelled sketch how this can be done.

**(Total for Question 15 is 3 marks)**

**16** Sam buys 20 boxes of oranges.  
There are 25 oranges in each box.

Each boxes of oranges costs £7

Sam sells  $\frac{2}{5}$  of the oranges he bought.

He sells each of these oranges for 40p.

He then sells each of the remaining oranges at 3 oranges for 50p.

Did Sam make a profit or did Sam make a loss?

You must show working to justify your answer.

DO NOT WRITE IN THIS AREA

DO NOT WRITE IN THIS AREA

DO NOT WRITE IN THIS AREA

**(Total for Question 16 is 5 marks)**

DO NOT WRITE IN THIS AREA

DO NOT WRITE IN THIS AREA

DO NOT WRITE IN THIS AREA

17 100 students had some homework.

42 of these students are boys.

8 of the 100 students did **not** do their homework.

53 of the girls did do their homework.

(a) Use this information to complete the frequency tree.

(3)

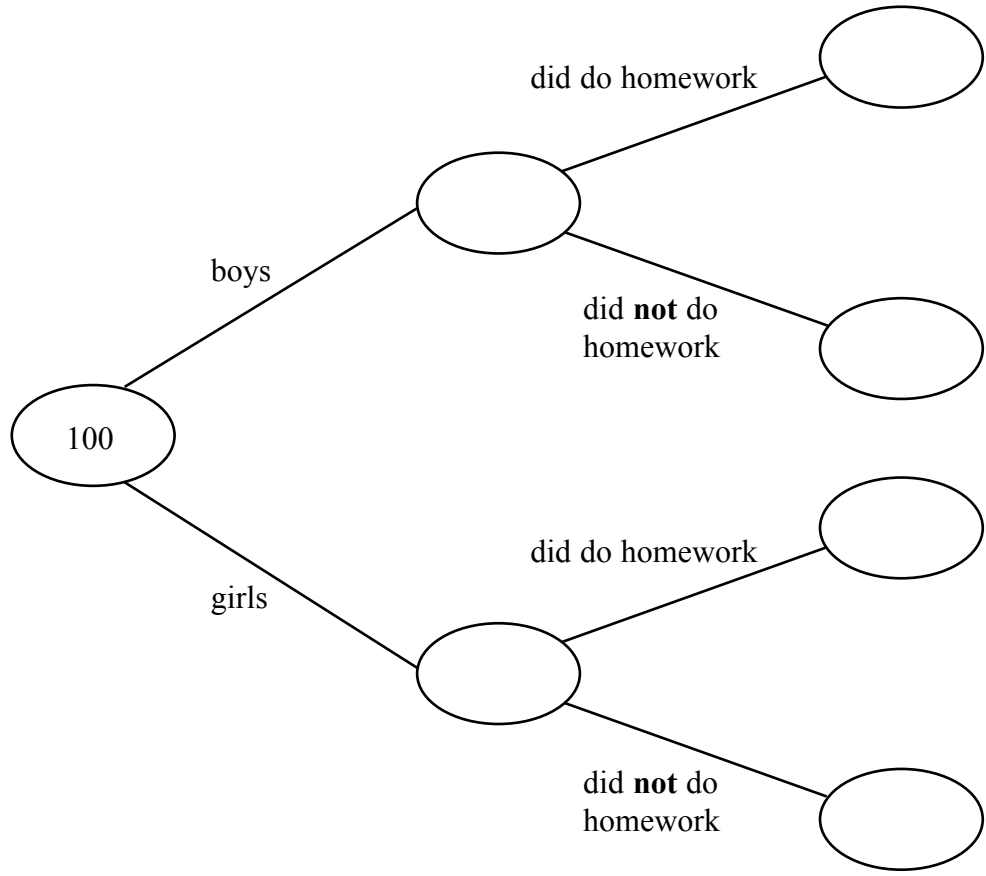

One of the girls is chosen at random.

(b) Work out the probability that this girl did **not** do her homework.

(2)

(Total for Question 17 is 5 marks)

18 (a) Work out  $\frac{2}{7} + \frac{1}{5}$

.....  
(2)

(b) Work out  $1\frac{2}{3} \div \frac{3}{4}$

.....  
(2)

**(Total for Question 18 is 4 marks)**

19 Solve  $4x + 5 = x + 26$

$x =$  .....

**(Total for Question 19 is 2 marks)**

DO NOT WRITE IN THIS AREA

DO NOT WRITE IN THIS AREA

DO NOT WRITE IN THIS AREA

- 20 In a sale, normal prices are reduced by 20%.  
The normal price of a coat is reduced by £15

Work out the normal price of the coat.

£.....

**(Total for Question 20 is 2 marks)**

- 21 Work out  $6.34 \times 5.2$

.....  
**(Total for Question 21 is 3 marks)**

22 Expand and simplify  $(m + 7)(m + 3)$

(Total for Question 22 is 2 marks)

23

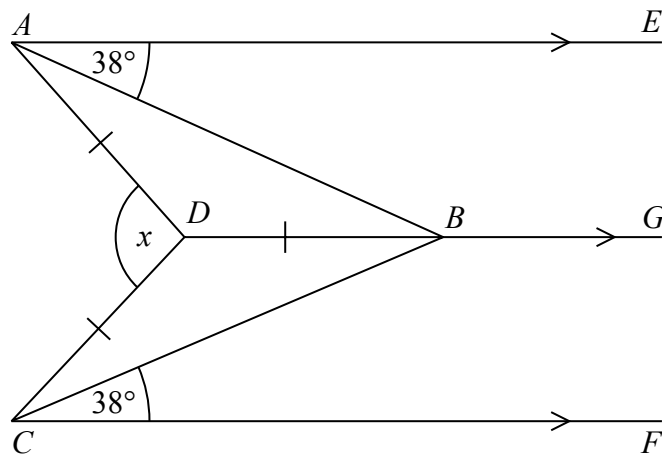

$AE$ ,  $DBG$  and  $CF$  are parallel.  
 $DA = DB = DC$ .  
Angle  $EAB = \text{angle } BCF = 38^\circ$

Work out the size of the angle marked  $x$ .  
You must show your working.

(Total for Question 23 is 3 marks)

DO NOT WRITE IN THIS AREA

DO NOT WRITE IN THIS AREA

DO NOT WRITE IN THIS AREA



DO NOT WRITE IN THIS AREA

DO NOT WRITE IN THIS AREA

DO NOT WRITE IN THIS AREA

24 Gary drove from London to Sheffield.  
It took him 3 hours at an average speed of 80 km/h.

Lyn drove from London to Sheffield.  
She took 5 hours.

Assuming that Lyn  
drove along the same roads as Gary  
and did not take a break,

(a) work out Lyn's average speed from London to Sheffield.

..... km/h  
(3)

(b) If Lyn did **not** drive along the same roads as Gary, explain how this could affect your answer to part (a).

.....  
.....  
(1)

**(Total for Question 24 is 4 marks)**

25 In a company, the ratio of the number of men to the number of women is 3 : 2

40% of the men are under the age of 25

10% of the women are under the age of 25

What percentage of all the people in the company are under the age of 25?

.....%

**(Total for Question 25 is 4 marks)**

DO NOT WRITE IN THIS AREA

DO NOT WRITE IN THIS AREA

DO NOT WRITE IN THIS AREA

DO NOT WRITE IN THIS AREA

DO NOT WRITE IN THIS AREA

DO NOT WRITE IN THIS AREA

26 The plan, front elevation and side elevation of a solid prism are drawn on a centimetre grid.

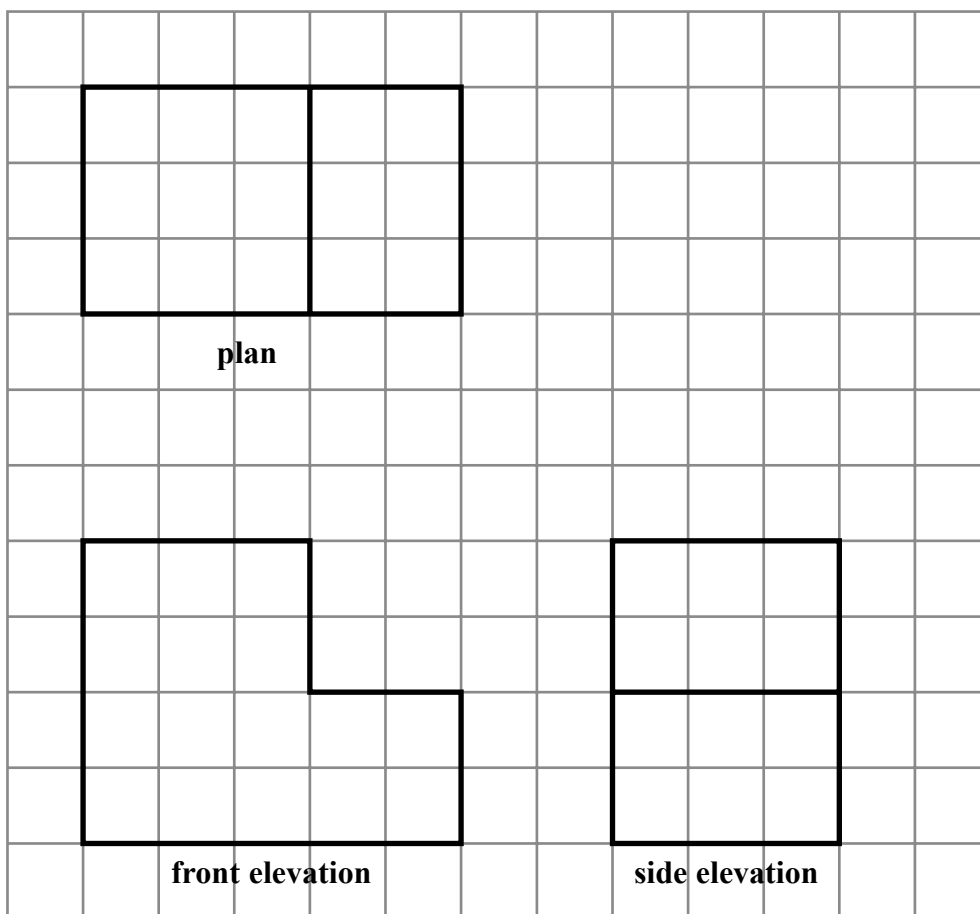

In the space below, draw a sketch of the solid prism.  
Write the dimensions of the prism on your sketch.

(Total for Question 26 is 2 marks)

27 There are 1200 students at a school.

Kate is helping to organise a party.  
She is going to order pizza.

Kate takes a sample of 60 of the students at the school.  
She asks each student to tell her **one** type of pizza they want.

The table shows information about her results.

Pizza	Number of students
ham	20
salami	15
vegetarian	8
margarita	17

Work out how much ham pizza Kate should order.

Write down any assumption you make **and** explain how this could affect your answer.

.....  
.....  
**(Total for Question 27 is 3 marks)**

DO NOT WRITE IN THIS AREA

DO NOT WRITE IN THIS AREA

DO NOT WRITE IN THIS AREA

28 Here is a parallelogram.

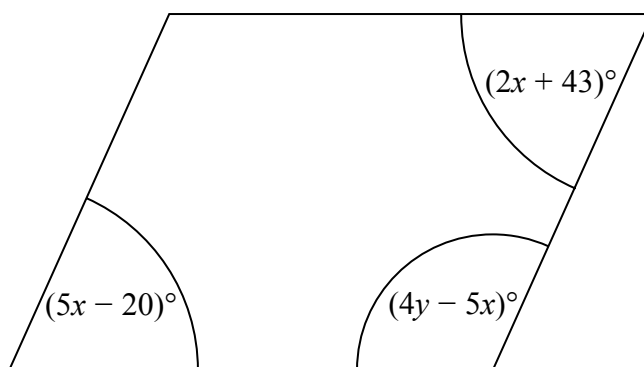

Work out the value of  $x$  and the value of  $y$ .

$x = \dots\dots\dots$

$y = \dots\dots\dots$

**(Total for Question 28 is 5 marks)**

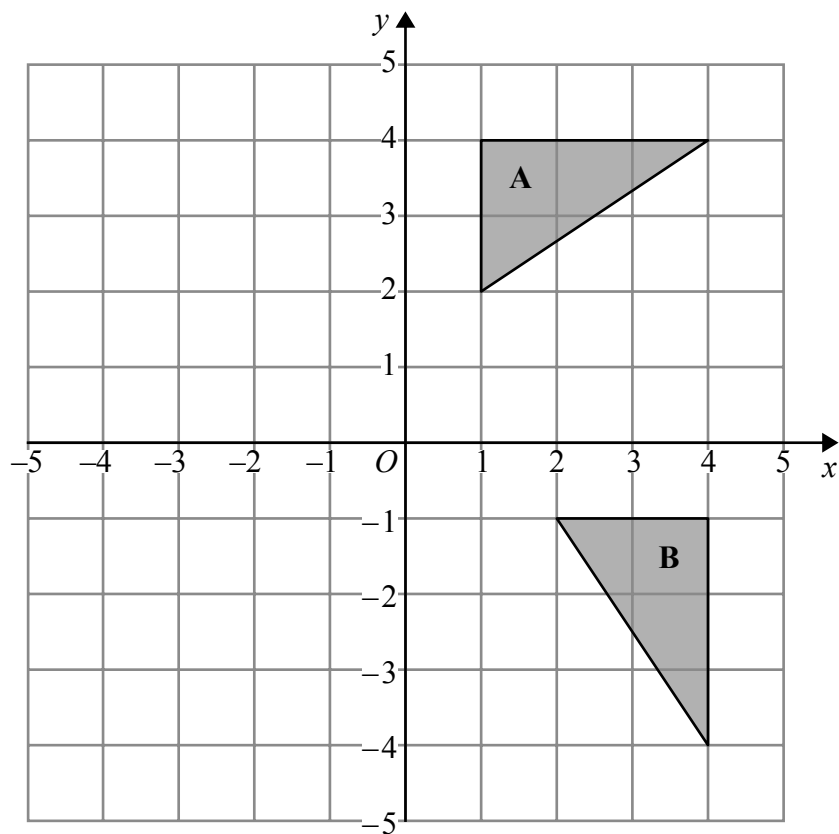

Describe fully the single transformation that maps triangle A onto triangle B.

.....

.....

(Total for Question 29 is 2 marks)

30  $\mathbf{a} = \begin{pmatrix} 3 \\ -7 \end{pmatrix}$ ,  $\mathbf{b} = \begin{pmatrix} 4 \\ 2 \end{pmatrix}$

Work out  $\mathbf{b} - 2\mathbf{a}$  as a column vector.

.....

(Total for Question 30 is 2 marks)

TOTAL FOR PAPER IS 80 MARKS

Paper 1MA1: 1F			
Question	Working	Answer	Notes
1		0.1,0.106,0.16,0.61	B1
2		$\frac{37}{1000}$	B1
3		39	B1
4		1, 2, 4, 5, 10, 20	M1 for at least 3 factors A1 for all factors with no additions
5		17	P1 start to process information eg. $130 \div 8$ <b>or</b> repeated subtraction from 130 <b>or</b> repeated addition A1 16.25 <b>or</b> 16 remainder 2 <b>or</b> 128 <b>or</b> 136 C1 allow ft - interprets answer to round up to integer value
6	(i)	$\times \text{ at } \frac{1}{2}$	B1
	(ii)	$\times \text{ at } \frac{4}{6}$	B1

Paper 1MA1: 1F			
Question	Working	Answer	Notes
7		7.50	M1 $60 \div 8$ A1 accept 7.5
8		12	M1 M1 for $0.15 \times 80$ oe <b>or</b> $8 + 4$ A1 cao
9		$\frac{1}{4}$	B1 $\frac{1}{4}$ oe
10		$\frac{2}{7}$	B1
11		6	M1 for starting to list combinations A1 cao
12 (a)		18	M1 Evidence of interpretation of pattern, eg. further diagrams drawn or numerical sequence for numbers of triangles 6, 8, 10 etc A1
(b)		No with reason	C1 No with reason eg. No , pattern number 6 will have 7 squares; always one more square than pattern number



Paper 1MA1: 1F			
Question	Working	Answer	Notes
13 (a)		2000	P1 Evidence of estimate eg. 400 or 20 used in calculation P1 complete process to solve problem A1
		Overestimate with reason	C1 fit from (a) eg. overestimate as two numbers rounded up
14 (a) (b)		5	B1
		Correct pie chart with labels	C1 For apples shown as 'half' ie 180° on pie chart C1 All angles calculated correctly (Angles of 180°, 80°, 100°) <b>or</b> pie chart with correct angles C1 Fully correct pie chart with labels of apple, pear and plum
15		Correct diagram with layout and lengths	M1 for changing to consistent units eg. 1000 ÷ 10 or 40 × 10 M1 for interpreting information and a process to fit tiles in floor area eg. may be seen in a sketch or a calculation C1 for a diagram to communicate a correct layout with lengths clearly identified
16		loss (supported by correct figures)	P1 process to find total spent eg. 20 × 7 (=140) P1 complete process to find profit from full price oranges eg. $\frac{2}{5} \times 25 \times 20 \times 40 (= 8000)$ P1 complete process to find profit from reduced price oranges eg. $50 \times \left( \frac{3}{5} \times 25 \times 20 \right) \div 3 (=5000)$ P1 complete process to find total income with consistent units A1 loss with £10 <b>or</b> -£10 <b>or</b> £130 <b>and</b> £140

Paper 1MA1: 1F			
Question	Working	Answer	Notes
17 (a)		42, 58 39, 3, 53, 5	C1 starts to interpret information eg. one correct frequency C1 continue to interpret information C1 communicates all information correctly
(b)		$\frac{5}{58}$	M1 ft for $\frac{a}{58}$ with $a < 58$ <b>or</b> $\frac{5}{b}$ with $b > 5$ A1 ft from (a)
18 (a)		$\frac{17}{35}$	M1 for common denominators with at least one numerator correct A1
(b)		$\frac{20}{9}$	M1 for $\frac{5}{3} \times \frac{4}{3}$ <b>or</b> $\frac{20}{12} \div \frac{9}{12}$ A1
19		7	M1 Correct method to isolate terms in $x$ A1
20		75	P1 for start to process eg. linking 20% with 15 or $100 \div 5 (=20)$ A1

Paper 1MA1: 1F			
Question	Working	Answer	Notes
21		32.968	M1 for correct method (condone one error) A1 for digits 32968 A1 ft (dep M1) for correct placement of decimal pt
22		$m^2 + 10m + 21$	M1 for at least 3 terms out of a maximum of 4 correct from expansion A1
23		152	M1 Start to method $ABD = 38^\circ$ <b>and</b> $BAD$ or $DBC$ or $DCB = 38^\circ$ M1 $ADB$ or $BDC = 180 - 2 \times 38 (=104)$ A1 for 152 with working
24	(a)	48	P1 start to process eg. $3 \times 80 (=240)$ P1 '240' $\div 5$ A1
	(b)		C1 eg. she may drive a different distance and therefore her average speed could be different

Paper 1MA1: 1F			
Question	Working	Answer	Notes
25		28	<p>P1 Process to start to solve problem eg. <math>\frac{3}{5} \times 40</math> or divide any number in the ratio 3:2</p> <p>P1 Second step in process to solve problem eg. <math>\frac{2}{5} \times 10</math> or find number of males/females under 25 for candidate's chosen number</p> <p>P1 for complete process</p> <p>A1</p>
26		Correct sketch	<p>C1 interprets diagram eg. draw a solid shape with at least two correct dimensions</p> <p>C1 draws correct prism with all necessary dimensions.</p>
27		400	<p>P1 Start to process eg. <math>1200 \div 60</math></p> <p>A1 400 oe (accept number of whole pizzas eg. <math>400 \div 4 = 100</math> with 4 people per pizza)</p> <p>C1 Eg. Assumption that sample is representative of population – it may not be all 1200 people are going to the party – need less pizza if they don't, assume 4 people per pizza – if different may need more/fewer pizzas</p>

Paper 1MA1: 1F			
Question	Working	Answer	Notes
28		$x = 21, y = 50$	P1 process to start solving problem eg. form an appropriate equation P1 complete process to isolate terms in $x$ A1 for $x = 21$ P1 complete process to find second variable A1 $y = 50$
29		Rotation of $90^\circ$ clockwise about $(0,0)$	M1 For two of 'rotation', $(0,0)$ , $90^\circ$ clockwise oe A1 Correct transformation
30		$\begin{pmatrix} -2 \\ 16 \end{pmatrix}$	C1 For $\begin{pmatrix} 4 \\ 2 \end{pmatrix} - 2 \begin{pmatrix} 3 \\ -7 \end{pmatrix}$ C1



Write your name here

Surname

Other names

**Pearson Edexcel**  
**Level 1/Level 2 GCSE (9 - 1)**

Centre Number

--	--	--	--	--

Candidate Number

--	--	--	--

# Mathematics

## Paper 2 (Calculator)

**Foundation Tier**

Sample Assessment Materials – Issue 2

**Time: 1 hour 30 minutes**

Paper Reference

**1MA1/2F**

**You must have:** Ruler graduated in centimetres and millimetres, protractor, pair of compasses, pen, HB pencil, eraser, calculator.

Total Marks

### Instructions

- Use **black** ink or ball-point pen.
- **Fill in the boxes** at the top of this page with your name, centre number and candidate number.
- Answer **all** questions.
- Answer the questions in the spaces provided – *there may be more space than you need.*
- **Calculators may be used.**
- If your calculator does not have a  $\pi$  button, take the value of  $\pi$  to be 3.142 unless the question instructs otherwise.
- Diagrams are **NOT** accurately drawn, unless otherwise indicated.
- You must **show all your working out.**



### Information

- The total mark for this paper is 80
- The marks for **each** question are shown in brackets – *use this as a guide as to how much time to spend on each question.*

### Advice

- Read each question carefully before you start to answer it.
- Keep an eye on the time.
- Try to answer every question.
- Check your answers if you have time at the end.

Turn over ►

S48573A

©2015 Pearson Education Ltd.

6/4/7/7/4/6/6/6/6/



**PEARSON**

**Answer ALL questions.**

**Write your answers in the spaces provided.**

**You must write down all the stages in your working.**

- 1 Write down the value of the 3 in the number 4376

.....  
**(Total for Question 1 is 1 mark)**

- 2 (a) Write  $\frac{7}{16}$  as a decimal.

.....  
**(Total for Question 2 is 1 mark)**

- 3 Here is a list of numbers

4    7    9    25    27    31    64

From the numbers in the list, write down a cube number.

.....  
**(Total for Question 3 is 1 mark)**

- 4 Find the value of  $(2.8 - 0.45)^2 + \sqrt[3]{5.832}$

.....  
**(Total for Question 4 is 2 marks)**

DO NOT WRITE IN THIS AREA

DO NOT WRITE IN THIS AREA

DO NOT WRITE IN THIS AREA



DO NOT WRITE IN THIS AREA

DO NOT WRITE IN THIS AREA

DO NOT WRITE IN THIS AREA

5 There are some boys and girls in a classroom.

The probability of picking at random a boy is  $\frac{1}{3}$

What is the probability of picking a girl?

.....  
**(Total for Question 5 is 1 mark)**

6 Jan writes down

one multiple of 9  
and two different factors of 40

Jan adds together her three numbers.  
Her answer is greater than 20 but less than 30

Find three numbers that Jan could have written down.

.....  
**(Total for Question 6 is 3 marks)**

- 7  $ABCD$  is a square.  
This diagram is drawn accurately.

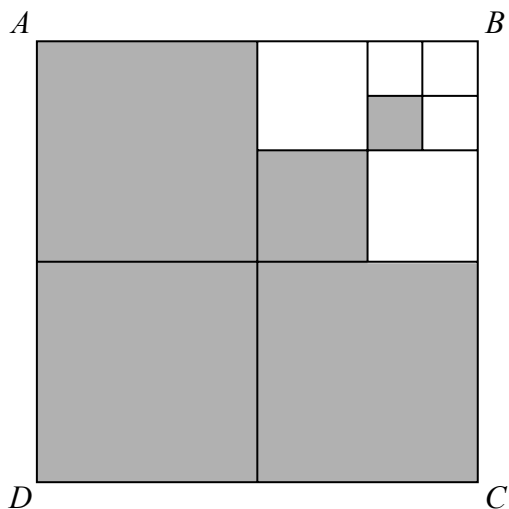

What fraction of the square  $ABCD$  is shaded?

(Total for Question 7 is 2 marks)

DO NOT WRITE IN THIS AREA

DO NOT WRITE IN THIS AREA

DO NOT WRITE IN THIS AREA

DO NOT WRITE IN THIS AREA

DO NOT WRITE IN THIS AREA

DO NOT WRITE IN THIS AREA

8 Sam and Max work in a shop from Monday to Friday.

Sam draws a graph to show the number of TVs they each sell.

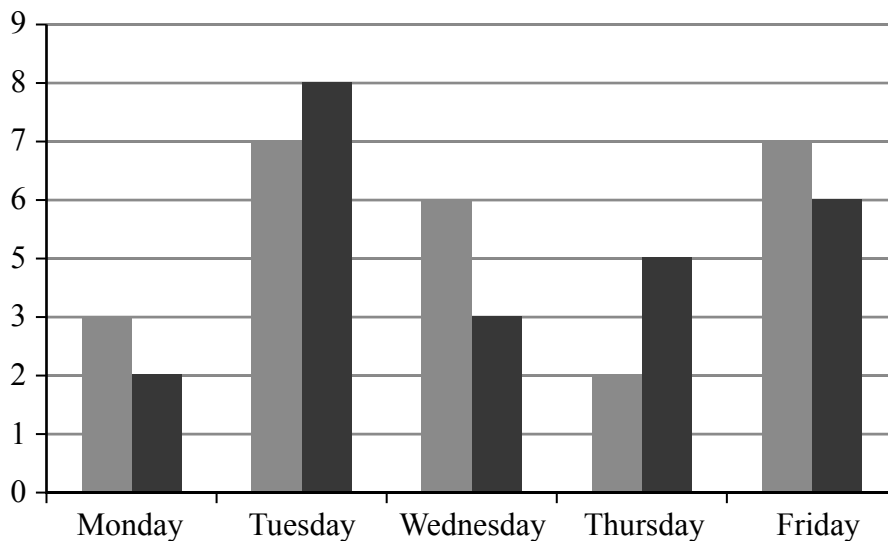

Write down **three** things that are wrong with this graph.

- 1 .....
- .....
- 2 .....
- .....
- 3 .....
- .....

**(Total for Question 8 is 3 marks)**

9 Here is a list of numbers

- 12    19    12    15    11    15    12    13    17

Find the median.

.....

**(Total for Question 9 is 2 marks)**

10 (a) Rob buys  $p$  packets of plain crisps and  $c$  packets of cheese crisps.

Write down an expression for the total number of packets of crisps Rob buys.

.....  
(1)

(b) Solve  $3x - 5 = 9$

$x =$  .....  
(2)

**(Total for Question 10 is 3 marks)**

11 Adam says,

“When you multiply an even number by an odd number  
the answer is always an odd number.”

(a) Write down an example to show Adam is wrong.

.....  
(1)

Betty says,

“When you multiply two prime numbers together  
the answer is always an odd number.”

(b) Betty is wrong.  
Explain why.

.....  
.....  
(2)

**(Total for Question 11 is 3 marks)**

DO NOT WRITE IN THIS AREA

DO NOT WRITE IN THIS AREA

DO NOT WRITE IN THIS AREA

12 You can use the information in the table to convert between kilometres and miles.

<b>miles</b>	0	5	20	40
<b>kilometres</b>	0	8	32	64

(a) Use this information to draw a conversion graph.

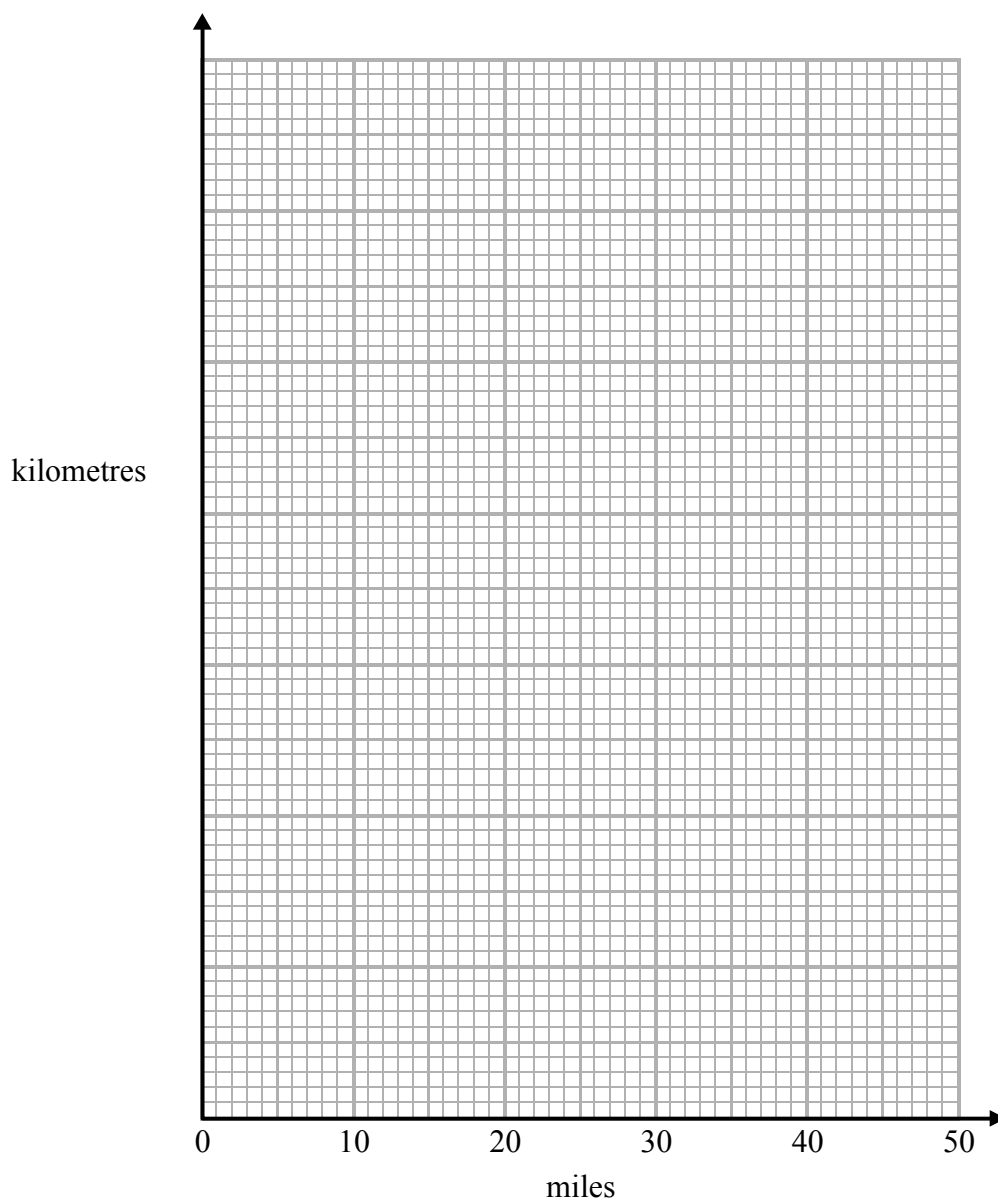

(3)

(b) Which is further, 20 kilometres or 15 miles?  
You must show how you got your answer.

(2)

**(Total for Question 12 is 5 marks)**

13

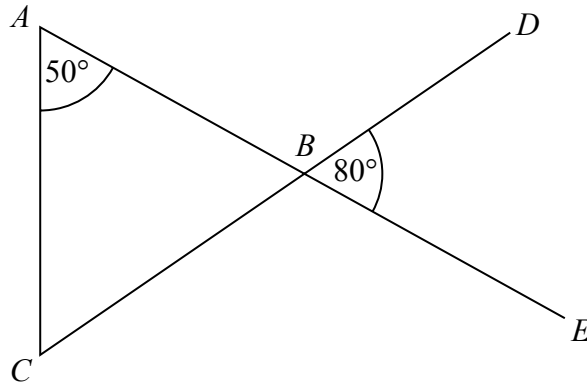

$ABE$  and  $CBD$  are straight lines.

Show that triangle  $ABC$  is an isosceles triangle.  
Give a reason for each stage of your working.

(Total for Question 13 is 4 marks)

DO NOT WRITE IN THIS AREA

DO NOT WRITE IN THIS AREA

DO NOT WRITE IN THIS AREA

DO NOT WRITE IN THIS AREA

DO NOT WRITE IN THIS AREA

DO NOT WRITE IN THIS AREA

- 14 The diagram shows a tank in the shape of a cuboid.  
It also shows a container in the shape of a cuboid.

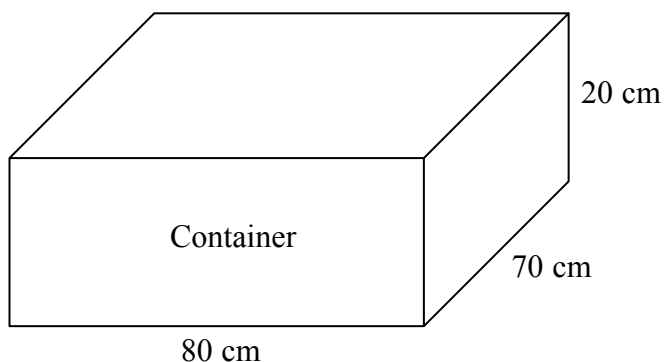
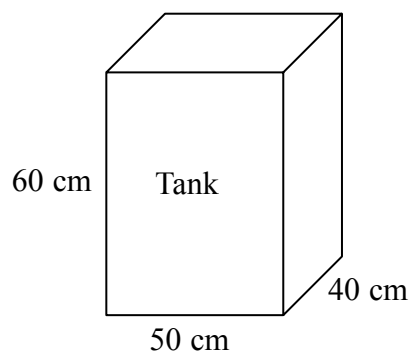

The tank is full of oil.  
The container is empty.

35% of the oil from the tank is spilled.  
The rest of the oil from the tank is put into the container.

Work out the height of the oil in the container.  
Give your answer to an appropriate degree of accuracy.

..... cm

**(Total for Question 14 is 5 marks)**

15 The diagram below represents two towns on a map.

Diagram  
**accurately** drawn

×  
Towey

×  
Worsley

Scale: 1 cm represents 3 kilometres.

Work out the distance, in kilometres, between Towey and Worsley.

..... km

**(Total for Question 15 is 2 marks)**

16 Find the Highest Common Factor (HCF) of 24 and 60

.....

**(Total for Question 16 is 2 marks)**

DO NOT WRITE IN THIS AREA

DO NOT WRITE IN THIS AREA

DO NOT WRITE IN THIS AREA



DO NOT WRITE IN THIS AREA

DO NOT WRITE IN THIS AREA

DO NOT WRITE IN THIS AREA

17 Soap powder is sold in three sizes of box.

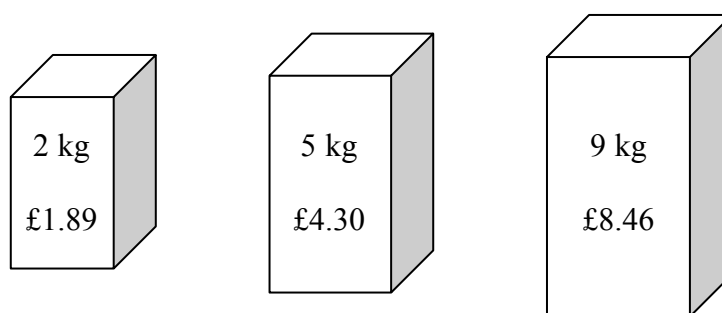

A 2 kg box of soap powder costs £1.89

A 5 kg box of soap powder costs £4.30

A 9 kg box of soap powder costs £8.46

Which size of box of soap powder is the best value for money?

You must show how you get your answer.

**(Total for Question 17 is 3 marks)**

18  $f = 5x + 2y$   
 $x = 3$  and  $y = -2$

Find the value of  $f$ .

(Total for Question 18 is 2 marks)

19 Jane made some almond biscuits which she sold at a fete.

She had:

5 kg of flour

3 kg of butter

2.5 kg of icing sugar

320 g of almonds

Here is the list of ingredients for making 24 almond biscuits.

Ingredients for 24 almond biscuits

150 g flour

100 g butter

75 g icing sugar

10 g almonds

Jane made as many almond biscuits as she could, using the ingredients she had.

Work out how many almond biscuits she made.

(Total for Question 19 is 3 marks)

DO NOT WRITE IN THIS AREA

DO NOT WRITE IN THIS AREA

DO NOT WRITE IN THIS AREA

DO NOT WRITE IN THIS AREA

DO NOT WRITE IN THIS AREA

DO NOT WRITE IN THIS AREA

20 (a) Factorise  $3f + 9$

.....  
(1)

(b) Factorise  $x^2 - 2x - 15$

.....  
(2)

**(Total for Question 20 is 3 marks)**

---

21  $q = \frac{p}{r} + s$

Make  $p$  the subject of this formula.

.....  
**(Total for Question 21 is 2 marks)**

---

22 A tin of varnish costs £15

A rectangular floor has dimensions 6 m by 11 m.  
The floor is going to be covered in varnish.

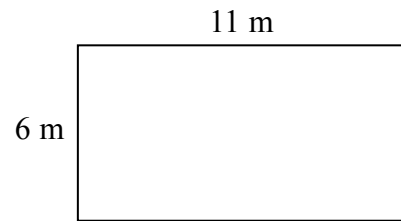

Helen assumes that each tin of this varnish covers an area of  $12 \text{ m}^2$ .

(a) Using Helen's assumption, work out the cost of buying the varnish for this floor.

£ .....  
(4)

Helen finds that each tin of varnish covers less than  $12 \text{ m}^2$ .

(b) Explain how this might affect the number of tins she needs to buy.

.....  
.....  
(1)

(Total for Question 22 is 5 marks)

DO NOT WRITE IN THIS AREA

DO NOT WRITE IN THIS AREA

DO NOT WRITE IN THIS AREA

DO NOT WRITE IN THIS AREA

DO NOT WRITE IN THIS AREA

DO NOT WRITE IN THIS AREA

23 Frank, Mary and Seth shared some sweets in the ratio 4 : 5 : 7  
Seth got 18 more sweets than Frank.

Work out the total number of sweets they shared.

(Total for Question 23 is 3 marks)

24  $PQR$  is a right-angled triangle.

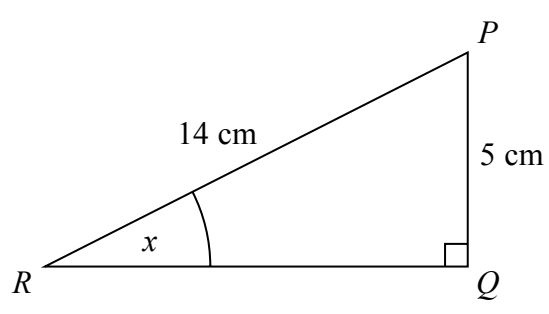

Work out the size of the angle marked  $x$ .  
Give your answer correct to 1 decimal place.

(Total for Question 24 is 2 marks)

25 Here are the first four terms of an arithmetic sequence.

6      10      14      18

(a) Write an expression, in terms of  $n$ , for the  $n$ th term of this sequence.

.....  
(2)

The  $n$ th term of a different arithmetic sequence is  $3n + 5$

(b) Is 108 a term of this sequence?  
Show how you get your answer.

(2)

**(Total for Question 25 is 4 marks)**

DO NOT WRITE IN THIS AREA

DO NOT WRITE IN THIS AREA

DO NOT WRITE IN THIS AREA

DO NOT WRITE IN THIS AREA

DO NOT WRITE IN THIS AREA

DO NOT WRITE IN THIS AREA

26 Axel and Lethna are driving along a motorway.

They see a road sign.

The road sign shows the distance to Junction 8

It also shows the average time drivers take to get to Junction 8

To Junction 8 30 miles 26 minutes
---

The speed limit on the motorway is 70 mph.

Lethna says

“We will have to drive faster than the speed limit to drive 30 miles in 26 minutes.”

Is Lethna right?

You must show how you get your answer.

(Total for Question 26 is 3 marks)

27 The table shows some information about the foot lengths of 40 adults.

Foot length ( $f$ cm)	Number of adults
$16 \leq f < 18$	3
$18 \leq f < 20$	6
$20 \leq f < 22$	10
$22 \leq f < 24$	12
$24 \leq f < 26$	9

(a) Write down the modal class interval.

.....  
(1)

(b) Calculate an estimate for the mean foot length.

..... cm  
(3)

**(Total for Question 27 is 4 marks)**



DO NOT WRITE IN THIS AREA

DO NOT WRITE IN THIS AREA

DO NOT WRITE IN THIS AREA

28 Triangles  $ABD$  and  $BCD$  are right-angled triangles.

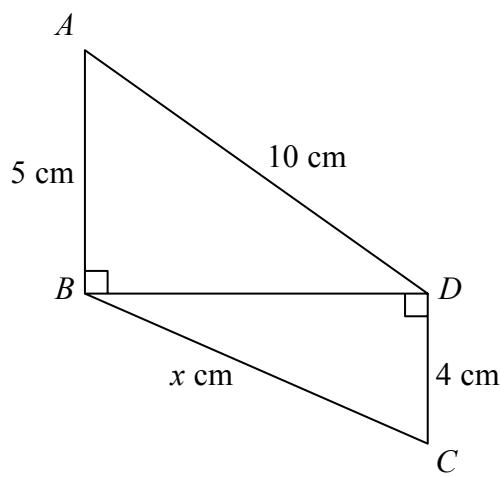

Work out the value of  $x$ .  
Give your answer correct to 2 decimal places.

.....  
**(Total for Question 28 is 4 marks)**

29 Here is a probability tree diagram.

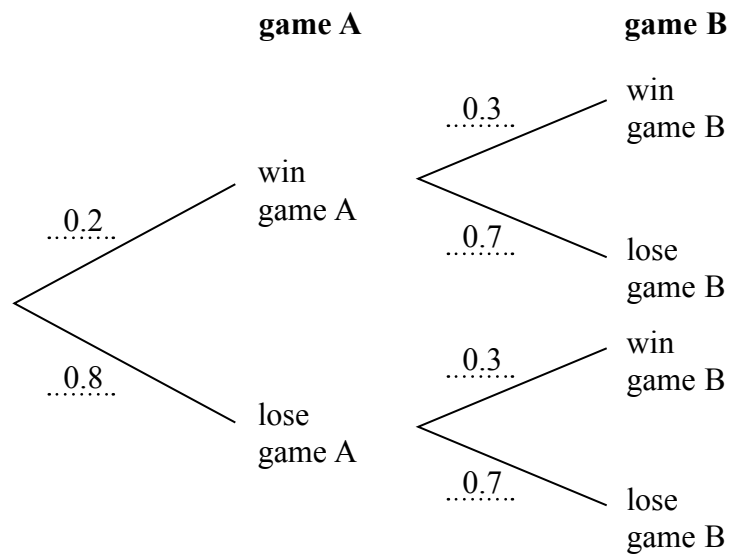

Work out the probability of winning both games.

(Total for Question 29 is 2 marks)

**TOTAL FOR PAPER IS 80 MARKS**

DO NOT WRITE IN THIS AREA

DO NOT WRITE IN THIS AREA

DO NOT WRITE IN THIS AREA

<b>Paper 1MA1: 2F</b>				
<b>Question</b>	<b>Working</b>	<b>Answer</b>	<b>Notes</b>	
1		6.66	B1 cao	
2		0.4375	B1 cao	
3		27 or 64	B1 cao	
4		7.3225	M1 for 5.5225 or 1.8 A1 cao	
5		$\frac{2}{3}$	B1 oe	
6		eg 1, 2, 18	P1 P1 A1	Starts process eg. Lists at least 2 multiples from 9, 18, 27, 36, 45 or lists at least 2 factors from 1, 2, 4, 5, 8, 10, 20, 40 Continues process eg. gives a set of numbers whose sum is greater than 20 but less than 30 but numbers may not all be appropriate factors/multiples Gives 3 numbers that meet all the criteria

Paper 1MA1: 2F		Working	Answer	Notes
7			$\frac{53}{64}$	P1 for interpreting information e.g. recognising that the shaded area = $3 \left( \frac{1}{4} \times \frac{1}{4} \right) + \left( \frac{1}{4} \times \frac{1}{4} \times \frac{1}{4} \right)$ or adding in lines to diagram to show 64ths A1 cao
8				C1 Any one correct statement eg. No key, $y$ axis label, 4 missing on $y$ axis C1 Any 2 <sup>nd</sup> correct statement C1 Any 3 <sup>rd</sup> correct statement
9			13	M1 Puts numbers in order or clear attempt to find 5 <sup>th</sup> number <b>or</b> $(9 + 1)/2$ <b>or</b> selects 11 A1
10	(a)		$p + c$	B1
	(b)		$\frac{14}{3}$	M1 adds 5 to both sides of equation A1 oe
11	(a)		eg. $2 \times 5 = 10$	B1 example given
	(b)		explanation	P1 two prime numbers identified C1 conclusion which also shows at least one calculation with prime numbers or identifies one of the prime numbers as 2.

Paper 1MA1: 2F			
Question	Working	Answer	Notes
12 (a)		graph	C1 introduce a scale for the y axis C1 plots at least 2 points correctly C1 fully correct and complete graph
(b)		15 miles (supported)	M1 reads off graph eg 20 km = 12-13 miles or 15 miles = 24 km or uses table C1 states 15 miles (24 km) with appropriate evidence
13		shown	B1 $ABC = 80$ M1 $180 - 80^\circ - 50^\circ$ A1 $ACB = 50$ C1 statement that since $ACB = CAB = 50^\circ$ with reasons eg <u>Vertically opposite angles are equal</u> , <u>Angles in a triangle add up to <math>180^\circ</math></u> , The <u>exterior angle of a triangle is equal to the sum of the interior opposite angles</u> ; <u>Base angles of an isosceles triangle are equal</u> .
14		13.9	P1 finds the volume of a cuboid eg $50 \times 40 \times 60 (=120000)$ P1 finds 35% of the oil from the cuboid eg $120000 \times 0.35$ oe $(=42000)$ P1 removes 35% of oil from cuboid eg $120000 - 42000 (=78000)$ P1 division to find missing side length eg $78000 \div (80 \times 70)$ or $13.928\dots$ A1 for answer to an appropriate degree of accuracy eg (13.9 or 14 or 10)

Paper 1MA1: 2F			Notes
Question	Working	Answer	
15		22.5	M1 interpret information eg use the scale A1
16		12	M1 Starts to list factors of writes at least one number in terms of prime factors <b>or</b> identifies a common factor other than 1 A1 cao
17	<p>£ per kg:  <math>1.89 \div 2 = 0.945</math> (94.5);  <math>4.30 \div 5 = 0.86</math> (86);  <math>8.46 \div 9 = 0.94</math> (94)</p> <p>kg per £:  <math>2 \div 1.89 = 1.058(2\dots)</math>;  <math>5 \div 4.30 = 1.162(79\dots)</math>;  <math>9 \div 8.46 = 1.0638(297\dots)</math></p> <p>Price per 90 kg:  <math>1.89 \times 45 = 85.05</math>;  <math>4.30 \times 18 = 77.4(0)</math>;  <math>8.46 \times 10 = 84.6(0)</math></p>	5 kg (supported)	P1 for a process (for at least two boxes) of division of price by quantity or division of quantity by price or a complete method to find price of same quantity or to find quantity of same price P1 for a complete process to give values that can be used for comparison of all 3 boxes C1 for 5 kg and correct values that can be used for comparison for all 3 boxes and a comparison of their values
18		11	M1 process of substitution demonstrated eg $5 \times 3 + 2 \times -2$ A1 cao

Paper 1MA1: 2F		Working	Answer	Notes
19			720	P1 attempt to find the maximum biscuits for one of the ingredients e.g. $5000 \div 15 (=33.3..)$ or $2500 \div 75 (=33.3..)$ or $3000 \div 100 (=30)$ or $320 \div 10 (=32)$ P1 for identifying butter as the limiting factor or $30 \times 24 (=720)$ seen A1
20	(a)		$3(f+3)$	B1 cao
	(b)		$(x-5)(x+3)$	M1 for $(x \pm 5)(x \pm 3)$ A1 cao
21			$p=qr-sr$	M1 for multiplying all 3 terms by $r$ or isolating $p/r$ term A1 oe
22	(a)		90	P1 for the process of finding an area eg $6 \times 11 (=66)$ P1 (dep on area calculation) for the process of working out the number of tins eg " $66$ " $\div 12 (=5.5$ or $6$ tins) P1 for the process of working out the cost eg " $6$ " tins $\times$ $\pounds 15$ A1 cao
	(b)		reason	C1 she might need to buy more tins

Paper 1MA1: 2F		Working	Answer	Notes
23			96	<p>P1 a strategy to start to solve the problem eg <math>18 \div (7 - 4) (=6)</math></p> <p>P1 for completing the process of solution eg “6” <math>\times (4 + 5 + 7)</math></p> <p>A1 cao</p>
24			20.9	<p>M1 correct recall of appropriate formula eg <math>\sin x = \frac{5}{14}</math></p> <p>A1 for 20.9(248...)</p>
25	(a)		$4n+2$	<p>M1 start to deduce nth term from information given eg <math>4n+k</math> where <math>k \neq 2</math></p> <p>A1 cao</p>
	(b)		No (supported)	<p>M1 start to method that could lead to a deduction eg uses inverse operations</p> <p>C1 for a convincing argument eg 34 is 107 so NO; <math>(108-5) \div 3</math> is not an integer</p>
26			<p>conclusion</p> <p>(supported)</p>	<p>P1 <math>30 \div 70 (=0.428)</math>      <math>26 \div 60 (=0.4333...)</math>      <math>30 \div 26 (=1.153...)</math></p> <p>P1 <math>60 \times "0.428..."</math>      <math>70 \times "0.4333..."</math>      <math>60 \times "1.153..."</math></p> <p>C1 for conclusion linked to 25.7 mins, 30.3 miles or 69.2 mph</p>



Paper 1MA1: 2F			
Question	Working	Answer	Notes
27		$22 \leq f < 24$	
(a)			B1
(b)		21.9	M1 $x \times f$ using midpoints M1 (dep on previous mark) " $x \times f$ " $\div 40$ A1 accept 22 if working seen
28		9.54	P1 $10^2 - 5^2 (=75)$ P1 " $75$ " $+ 4^2 (=91)$ P1 $\sqrt{(10^2 - 5^2 + 4^2)}$ A1 $9.53 - 9.54$
29		0.06	M1 for 0.2 and 0.3 A1 cao



Write your name here

Surname

Other names

**Pearson Edexcel**  
**Level 1/Level 2 GCSE (9 - 1)**

Centre Number

--	--	--	--	--

Candidate Number

--	--	--	--

# Mathematics

## Paper 3 (Calculator)

**Foundation Tier**

Sample Assessment Materials - Issue 2

**Time: 1 hour 30 minutes**

Paper Reference

**1MA1/3F**

**You must have:** Ruler graduated in centimetres and millimetres, protractor, pair of compasses, pen, HB pencil, eraser, calculator.

Total Marks

### Instructions

- Use **black** ink or ball-point pen.
- **Fill in the boxes** at the top of this page with your name, centre number and candidate number.
- Answer **all** questions.
- Answer the questions in the spaces provided – *there may be more space than you need.*
- **Calculators may be used.**
- If your calculator does not have a  $\pi$  button, take the value of  $\pi$  to be 3.142 unless the question instructs otherwise.
- Diagrams are **NOT** accurately drawn, unless otherwise indicated.
- You must **show all your working out.**



### Information

- The total mark for this paper is 80
- The marks for **each** question are shown in brackets – *use this as a guide as to how much time to spend on each question.*

### Advice

- Read each question carefully before you start to answer it.
- Keep an eye on the time.
- Try to answer every question.
- Check your answers if you have time at the end.

Turn over ►

S48575A

©2015 Pearson Education Ltd.

6/4/7/4/6/6/6/



**PEARSON**

**Answer ALL questions.**

**Write your answers in the spaces provided.**

**You must write down all the stages in your working.**

- 1 Write 2148 correct to the nearest 100

.....  
**(Total for Question 1 is 1 mark)**

---

- 2 (a) Simplify  $8x - 3x + 2x$

.....  
**(1)**

- (b) Simplify  $4y \times 2y$

.....  
**(1)**

**(Total for Question 2 is 2 marks)**

---

- 3 There are 6760 people at a rugby match.  
3879 of the people are men.  
1241 of the people are women.  
 $\frac{1}{4}$  of the children are girls.

Work out how many boys are at the rugby match.

.....  
**(Total for Question 3 is 3 marks)**

---

DO NOT WRITE IN THIS AREA

DO NOT WRITE IN THIS AREA

DO NOT WRITE IN THIS AREA

4 Here is a grid showing the points  $A$ ,  $B$  and  $C$ .

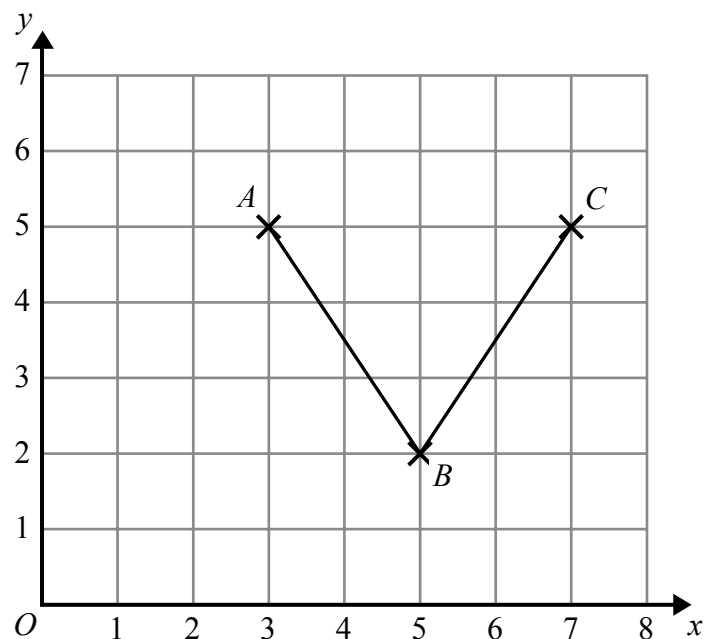

(a) Write down the coordinates of the point  $A$ .

.....  
(1)

(b) On the grid, mark with a cross ( $\times$ ) the point  $(1, 2)$ .  
Label this point  $D$ .

(1)

(c) On the grid, mark with a cross ( $\times$ ) a point  $E$ , so that the quadrilateral  $ABCE$  is a kite.

(1)

**(Total for Question 4 is 3 marks)**

5 Faiza buys

- one magazine costing £2.30
- one paper costing 92p
- two** identical bars of chocolate

Faiza pays with a £5 note.  
She gets 40p change.

Work out the cost of **one** bar of chocolate.

.....  
**(Total for Question 5 is 3 marks)**

6 The bar chart gives information about the numbers of students in the four Year 11 classes at Trowton School.

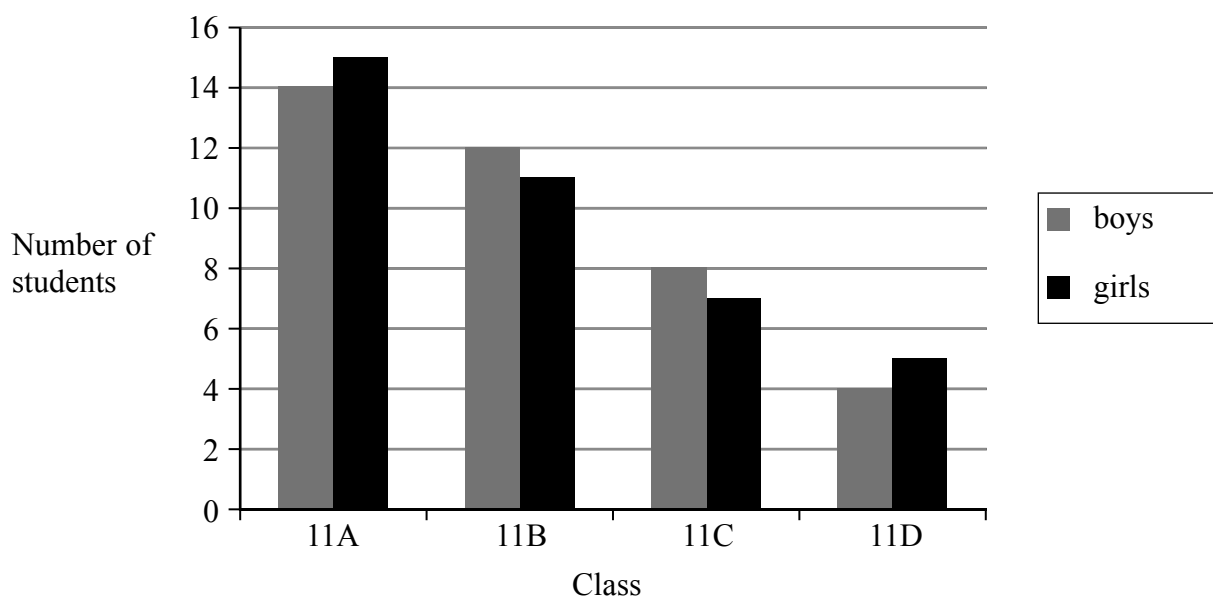

(a) What fraction of the students in class 11A are girls?

.....  
(2)

Shola says,

“There are more boys than girls in Year 11 in Trowton School.”

(b) Is Shola correct?

You must give a reason for your answer.

.....  
.....  
(2)

The pie chart gives information about the 76 students in the same four Year 11 classes at Trowton School.

**Number of students in Year 11 of Trowton School**

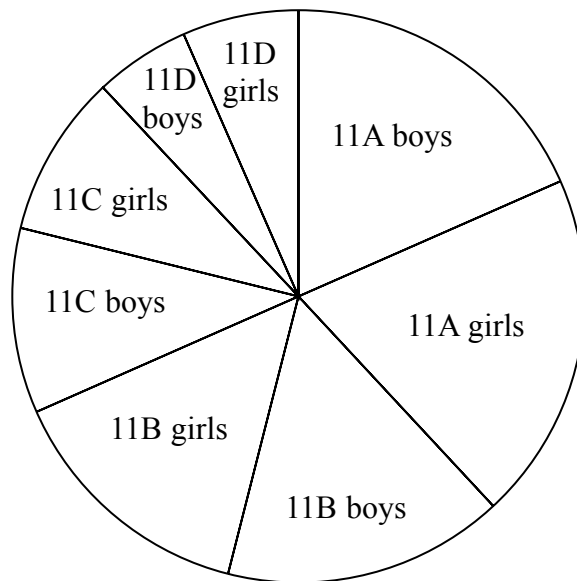

Tolu says,

“It is more difficult to find out the numbers of students in each class from the pie chart than from the bar chart.”

(c) Is Tolu correct?

You must give a reason for your answer.

(1)

**(Total for Question 6 is 5 marks)**

7 Here is a number machine.

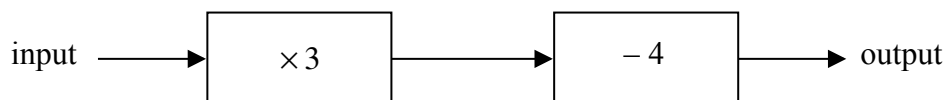

(a) Work out the **output** when the input is 4

.....  
(1)

(b) Work out the **input** when the output is 11

.....  
(2)

(c) Show that there is a value of the input for which the input and the output have the same value.

(2)

**(Total for Question 7 is 5 marks)**

DO NOT WRITE IN THIS AREA

DO NOT WRITE IN THIS AREA

DO NOT WRITE IN THIS AREA



DO NOT WRITE IN THIS AREA

- 8 1 yard is 36 inches.  
10 cm is an approximation for 4 inches.

Work out an approximation for the number of cm in 2 yards.

.....  
**(Total for Question 8 is 3 marks)**

- 9 Work out 234% of 150

.....  
**(Total for Question 9 is 2 marks)**

DO NOT WRITE IN THIS AREA

DO NOT WRITE IN THIS AREA

**10** Here are four numbers.

0.43

$\frac{3}{7}$

43.8%

$\frac{7}{16}$

Write these numbers in order of size.  
Start with the smallest number.

.....  
**(Total for Question 10 is 2 marks)**

**11** Here is a list of five numbers.

14

15

16

17

18

From the list,

(i) write down the prime number,

(ii) write down the square number.

.....  
**(Total for Question 11 is 2 marks)**

DO NOT WRITE IN THIS AREA

DO NOT WRITE IN THIS AREA

DO NOT WRITE IN THIS AREA

12 Here is a star shape.

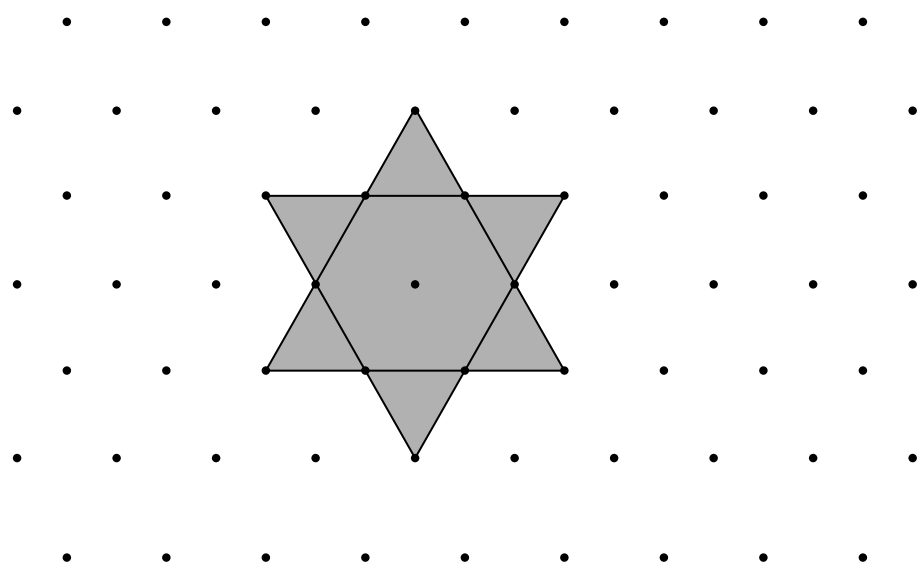

The star shape is made from a regular hexagon and six congruent equilateral triangles.

The area of the star shape is  $96 \text{ cm}^2$ .

Work out the area of the regular hexagon.

.....  $\text{cm}^2$

**(Total for Question 12 is 2 marks)**

13

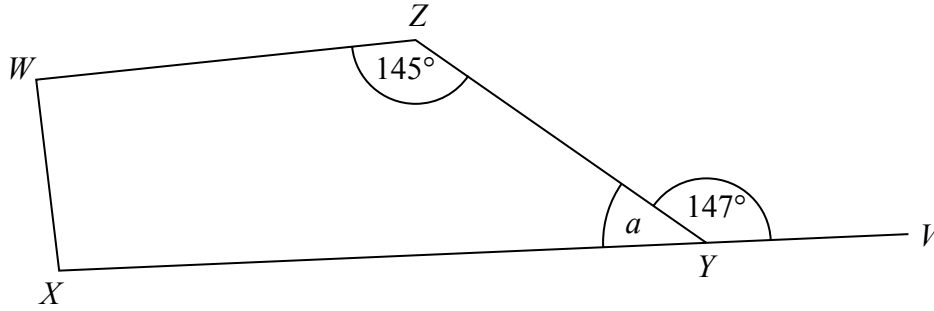

$WXYZ$  is a quadrilateral.  
 $XYV$  is a straight line.

(a) (i) Find the size of the angle marked  $a$ .

.....  
o

(ii) Give a reason for your answer.

.....  
(2)

Angle  $ZWX =$  angle  $WXY$

(b) Work out the size of angle  $ZWX$ .

.....  
o

(2)

**(Total for Question 13 is 4 marks)**

DO NOT WRITE IN THIS AREA

DO NOT WRITE IN THIS AREA

DO NOT WRITE IN THIS AREA

- 14 The total weight of 3 tins of beans and 4 jars of jam is 2080 g.  
The total weight of 5 tins of beans is 2000 g.

Work out the weight of 1 tin of beans and the weight of 1 jar of jam.

tin of beans..... g

jar of jam..... g

**(Total for Question 14 is 4 marks)**

---

15 There are 25 boys and 32 girls in a club.

$\frac{2}{5}$  of the boys and  $\frac{1}{2}$  of the girls walk to the club.

The club leader picks at random a child from the children who walk to the club.

Work out the probability that this child is a boy.

.....  
**(Total for Question 15 is 3 marks)**

DO NOT WRITE IN THIS AREA

DO NOT WRITE IN THIS AREA

DO NOT WRITE IN THIS AREA

DO NOT WRITE IN THIS AREA

DO NOT WRITE IN THIS AREA

DO NOT WRITE IN THIS AREA

16 Change 72 km/h into m/s.

.....m/s

**(Total for Question 16 is 3 marks)**

17 Here is a rectangle made of card.

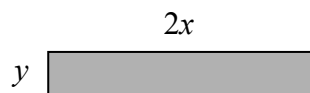

The measurements in the diagram are in centimetres.

Lily fits four of these rectangles together to make a frame.

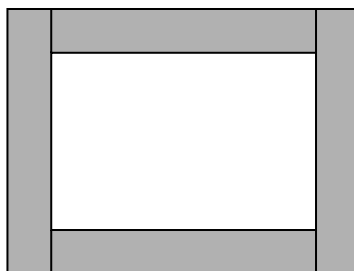

The perimeter of the inside of the frame is  $P$  cm.

(a) Show that  $P = 8x - 4y$

(2)

Magda says,

“When  $x$  and  $y$  are whole numbers,  $P$  is always a multiple of 4.”

(b) Is Magda correct?

You must give a reason for your answer.

(2)

**(Total for Question 17 is 4 marks)**

DO NOT WRITE IN THIS AREA

DO NOT WRITE IN THIS AREA

DO NOT WRITE IN THIS AREA



DO NOT WRITE IN THIS AREA

DO NOT WRITE IN THIS AREA

DO NOT WRITE IN THIS AREA

18 The diagram shows a trapezium  $ABCD$  and two identical semicircles.

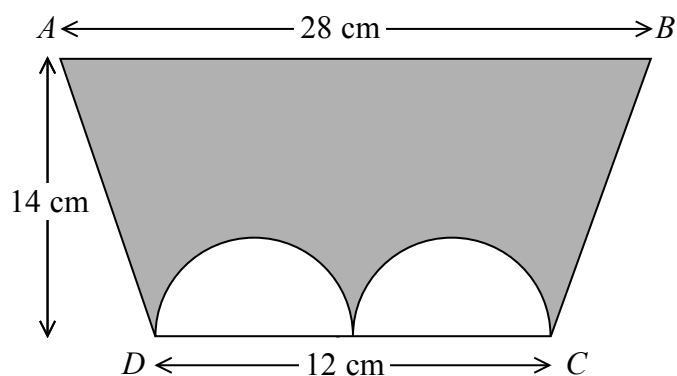

The centre of each semicircle is on  $DC$ .

Work out the area of the shaded region.

Give your answer correct to 3 significant figures.

.....  $\text{cm}^2$

**(Total for Question 18 is 4 marks)**

19 Asif is going on holiday to Turkey.

The exchange rate is  $\text{£}1 = 3.5601$  lira.

Asif changes  $\text{£}550$  to lira.

- (a) Work out how many lira he should get.  
Give your answer to the nearest lira.

..... lira  
(2)

Asif sees a pair of shoes in Turkey.  
The shoes cost 210 lira.

Asif does not have a calculator.

He uses  $\text{£}2 = 7$  lira to work out the approximate cost of the shoes in pounds.

- (b) Use  $\text{£}2 = 7$  lira to show that the approximate cost of the shoes is  $\text{£}60$

(2)

- (c) Is using  $\text{£}2 = 7$  lira instead of using  $\text{£}1 = 3.5601$  lira a sensible start to Asif's method to work out the cost of the shoes in pounds?

You must give a reason for your answer.

.....  
.....  
(1)

**(Total for Question 19 is 5 marks)**

20 Here are the first six terms of a Fibonacci sequence.

1    1    2    3    5    8

The rule to continue a Fibonacci sequence is,

the next term in the sequence is the sum of the two previous terms.

(a) Find the 9th term of this sequence.

.....  
(1)

The first three terms of a different Fibonacci sequence are

$a$      $b$      $a + b$

(b) Show that the 6th term of this sequence is  $3a + 5b$

(2)

Given that the 3rd term is 7 and the 6th term is 29,

(c) find the value of  $a$  and the value of  $b$ .

$a =$  .....

$b =$  .....

(3)

**(Total for Question 20 is 6 marks)**

- 21 In a survey, the outside temperature and the number of units of electricity used for heating were recorded for ten homes.

The scatter diagram shows this information.

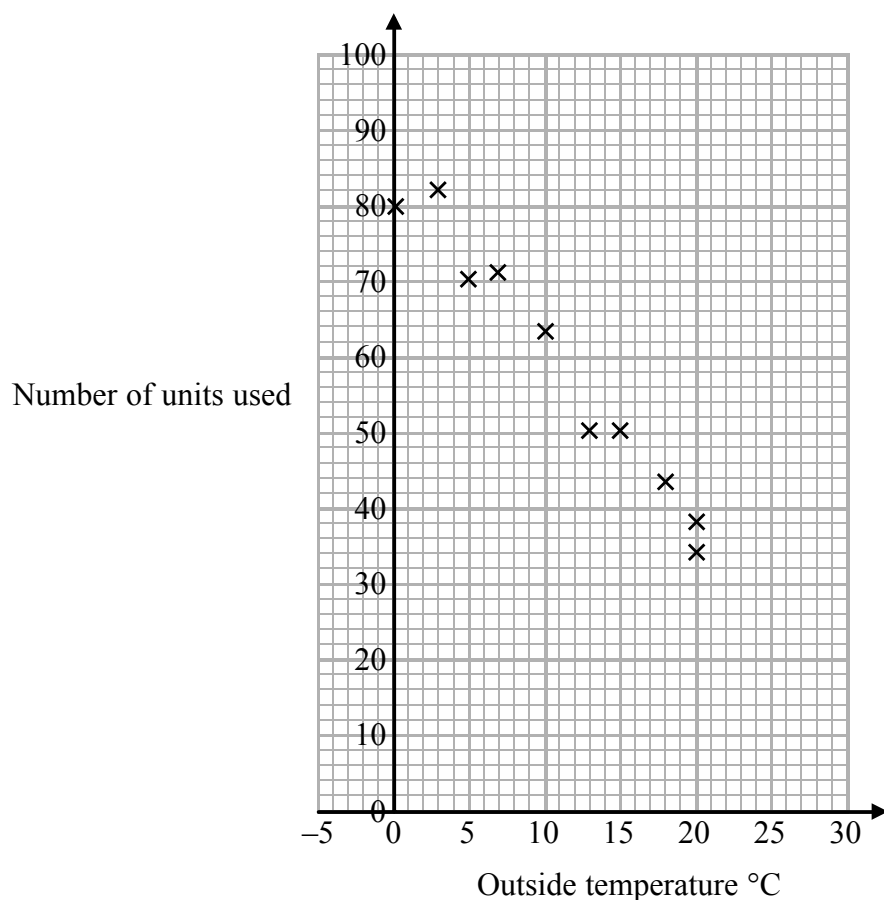

Molly says,

“On average the number of units of electricity used for heating decreases by 4 units for each °C increase in outside temperature.”

- (a) Is Molly right?  
Show how you get your answer.

(3)

- (b) You should **not** use a line of best fit to predict the number of units of electricity used for heating when the outside temperature is 30°C.

Give one reason why.

(1)

(Total for Question 21 is 4 marks)

22 Henry is thinking of having a water meter.

These are the two ways he can pay for the water he uses.

**Water Meter**

A charge of £28.20 per year

**plus**

91.22p for every cubic metre of water used

1 cubic metre = 1000 litres

**No Water Meter**

A charge of £107 per year

Henry uses an average of 180 litres of water each day.

Use this information to determine whether or not Henry should have a water meter.

**(Total for Question 22 is 5 marks)**

23 A and B are two companies.

The table shows some information about the sales of each company and the number of workers for each company in 2004 and in 2014

	Company A		Company B	
	Sales (£ millions)	Number of workers	Sales (£ millions)	Number of workers
2004	320	2960	48	605
2014	388	3200	57	640

(a) Work out the percentage increase in sales from 2004 to 2014 for Company A.

..... %  
(2)

(b) Which company had the most sales per worker in 2014, Company A or Company B?  
You must show how you get your answer.

(3)

(Total for Question 23 is 5 marks)

**TOTAL FOR PAPER IS 80 MARKS**

Paper 1MA1: 3F			
Question	Working	Answer	Notes
1		2100	B1
2 (a)		$7x$	B1
(b)		$8y^2$	B1
3		1230	P1 for start to process eg. $6760 - 3879 - 1241 (=1640)$ P1 for use of fraction eg. “1640” $\div$ 4 or $1 - \frac{1}{4} \left( = \frac{3}{4} \right)$ A1
4 (a)		(3, 5)	B1
(b)		Plotted	B1
(c)		eg. (5,6) plotted	B1
5	$(500 - 230 - 92 - 40) \div 2$	69p	P1 for start to process eg. $230 + 92$ or $500 - 40$ P1 for complete process A1 for 69p or £0.69

Paper 1MA1: 3F																
Question	Working	Answer	Notes													
6 (a)		$\frac{15}{29}$	M1	for $\frac{15}{a}$ where $a > 15$ or $\frac{b}{29}$ where $b < 29$ <b>or</b> correct fraction for girls from a different class												
(b)	11A + 1G, 11B - 1G 11C - 1G, 11D + 1G	No + reason	A1													
(c)		Yes + reason	M1	For complete method to find the sum of the signed differences in numbers of boys and girls or the totals of boys and girls in year 11												
			C1	'No' with correct argument eg. there are 38 boys and 38 girls												
			C1	'Yes' with eg. as many calculations using the angles would be required oe												
7 (a)		8	B1													
(b)	11 + 4 = 15 15 ÷ 3 = 5	5	M1	Start of method												
(c)	<table border="1"> <tr> <td>in</td> <td>0</td> <td>1</td> <td>2</td> <td>3</td> <td>4</td> </tr> <tr> <td>out</td> <td>-4</td> <td>-1</td> <td>2</td> <td>5</td> <td>8</td> </tr> </table>	in	0	1	2	3	4	out	-4	-1	2	5	8	2	A1	
in	0	1	2	3	4											
out	-4	-1	2	5	8											
			M1	For complete method that leads to answer e.g table of values or $x = 3x - 4$												
			C1	For 2 or for statement that the equation has a unique solution												
8		180	M1	For start to method e.g. $36 \div 4 (= 9)$ or $2 \times 36$												
			M1	For complete method to find no of cm in 1 yard <b>or</b> in 2 yards												
			A1													
9		351	M1	for $2.34 \times 150$ oe												
			A1													



Paper 1MA1: 3F			
Question	Working	Answer	Notes
10	0.43, 0.428..., 0.438. 0.4375	$\frac{3}{7}$ , 0.43, $\frac{7}{16}$ , 43.8%,	M1 A1 Converts numbers to common format e.g decimals to at least 3 d.p.
11 (i)		17	B1
(ii)	1	16	B1
12		48	P1 A1 For start to process eg. $96 \div 12$ <b>or</b> $96 \div 2$ cao
13 (a)(i)		33	B1
(ii)		The sum of the angles on a straight line is 180	B1
(b)	$(360 - 33 - 145) \div 2$	91	P1 A1 For a correct process to find angle <i>ZWX</i>
14	$2000 \div 5 = 400$ $2080 - 3 \times 400 = 880$ $880 \div 4$	400, 220	B1 P1 P1 A1 for 400 (weight of beans) Process to find total weight of 4 jars of jam Process to find weight of 1 jar of jam
15	$25 \div 5 \times 2 = 10$ $32 \div 2 = 16$ $\frac{10}{10 + 16}$	$\frac{10}{26}$	P1 P1 A1 Process to find number of boys walking and number of girls walking Complete process to find probability $\frac{10}{26}$ oe

Paper 1MA1: 3F			
Question	Working	Answer	Notes
16		20	M1 for conversion of km to metres or hours to minutes M1 for conversion of hours to seconds A1 cao
17 (a)	$2x + 2x - 2y + 2x + 2x - 2y$	Shown	M1 For method to acquire correct inside lengths C1 For completion
(b)	8x and 4y are multiples of 4 Their difference must be a multiple of 4 Or $4(2x - y)$ is a multiple of 4	Shown	M1 For method to start argument eg. factorise expression C1 For complete argument
18		252	P1 For start to process eg. radius = $12 \div 4 (=3)$ M1 Method to find area of trapezium or semicircle or circle P1 Process to find area of the shaded region A1 251.7 – 252
19 (a)	$550 \times 3.5601$	1958	M1 $550 \times 3.5601$ A1
(b)	$210 \div 7 \times 2 = 30 \times 2$ Or $60 \div 2 = 30$ and $30 \times 7 = 210$	Shown	M1 For correct method to convert cost in UK to lira or vice versa, using Asif's approximation C1 Shown with correct calculations
(c)		Correct evaluation	C1 For an evaluation e.g. It is a sensible start to the method because he can do the calculations without a calculator and 3.5 lira to the £ is a good approximation

Paper 1MA1: 3F			Notes
Question	Working	Answer	
20 (a)	8, 13, 21,	34	B1 cao
(b)	$a, b, a + b, a + 2b, 2a + 3b$	Shown	M1 Method to show by adding pairs of successive terms $a + 2b, 2a + 3b$ shown
(c)	$3a + 5b = 29$ $a + b = 7$ $3a + 3b = 21$ $b = 4, a = 3$	$a = 3$ $b = 4$	C1 P1 P1 A1 Process to set up two equations Process to solve equations
21 (a)	Draws LOBF Finds ht-base = $\frac{85 - 20}{0 - 25} = -2.6$	No + reason	M1 Interpret question eg. draw line of best fit $\frac{85 - 20}{0 - 25} = -2.6$ Start to test eg. gradient e.g.
(b)		The LOBF would have to be used outside the data	C1 C1 Gradient within range $\neq (2 - 3)$ and 'no' Convincing explanation
22		Have a water meter (from working with correct figures)	P1 P1 P1 P1 A1 Process to find number of litres eg. $180 \div 1000$ Full process to find cost per day Full process to find total cost of water used per year (accept use of alternative time period for both options) Full process with consistent units for total cost of water Correct decision from correct figures (88.13154 or correct figure for their time period)

Paper 1MA1: 3F		Working	Answer	Notes
Question				
23 (a)		$\frac{388 - 320}{320} \times 100 =$	21.25	M1 For a complete method A1 21.25%
(b)		A $388 \text{ (million)} \div 3200 =$ $\text{£}0.12125 \text{ million (}\text{£}121\,250\text{)}$ B $57 \text{ (million)} \div 640 =$ $\text{£}0.0890625 \text{ million (}\text{£}89062.50\text{)}$	Company A + evidence	M1 Method to find sales/person for A <b>or</b> B for 2014 A1 $\text{£}121\,250$ or $\text{£}89062.50$ C1 Company A with $\text{£}121\,250$ and $\text{£}89062.50$

Write your name here

Surname

Other names

**Pearson Edexcel**  
**Level 1/Level 2 GCSE (9 - 1)**

Centre Number

--	--	--	--	--

Candidate Number

--	--	--	--

# Mathematics

## Paper 1 (Non-Calculator)

**Higher Tier**

Sample Assessment Materials – Issue 2

**Time: 1 hour 30 minutes**

Paper Reference

**1MA1/1H**

**You must have:** Ruler graduated in centimetres and millimetres, protractor, pair of compasses, pen, HB pencil, eraser.

Total Marks



### Instructions

- Use **black** ink or ball-point pen.
- **Fill in the boxes** at the top of this page with your name, centre number and candidate number.
- Answer **all** questions.
- Answer the questions in the spaces provided – *there may be more space than you need.*
- **Calculators may not be used.**
- Diagrams are **NOT** accurately drawn, unless otherwise indicated.
- You must **show all your working out.**

### Information

- The total mark for this paper is 80
- The marks for **each** question are shown in brackets – *use this as a guide as to how much time to spend on each question.*

### Advice

- Read each question carefully before you start to answer it.
- Keep an eye on the time.
- Try to answer every question.
- Check your answers if you have time at the end.

Turn over ►

S48572A

©2015 Pearson Education Ltd.

6/4/17/14/6/6/



**PEARSON**

**Answer ALL questions.**

**Write your answers in the spaces provided.**

**You must write down all the stages in your working.**

**1** Work out  $6.34 \times 5.2$

.....  
**(Total for Question 1 is 3 marks)**

---

**2** Expand and simplify  $(m + 7)(m + 3)$

.....  
**(Total for Question 2 is 2 marks)**

---

DO NOT WRITE IN THIS AREA

DO NOT WRITE IN THIS AREA

DO NOT WRITE IN THIS AREA

3

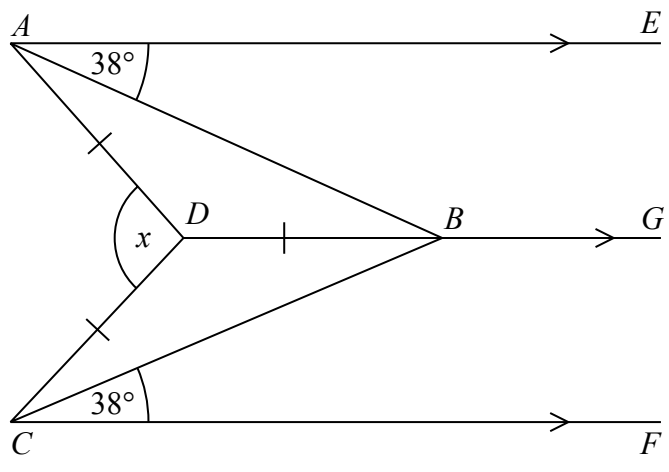

$AE$ ,  $DBG$  and  $CF$  are parallel.  
 $DA = DB = DC$ .  
Angle  $EAB = \text{angle } BCF = 38^\circ$

Work out the size of the angle marked  $x$ .  
You must show your working.

(Total for Question 3 is 3 marks)

4 Gary drove from London to Sheffield.  
It took him 3 hours at an average speed of 80km/h.

Lyn drove from London to Sheffield.  
She took 5 hours.

Assuming that Lyn  
drove along the same roads as Gary  
and did not take a break,

(a) work out Lyn's average speed from London to Sheffield.

..... km/h  
(3)

(b) If Lyn did **not** drive along the same roads as Gary, explain how this could affect your answer to part (a).

.....  
.....  
(1)

**(Total for Question 4 is 4 marks)**



DO NOT WRITE IN THIS AREA

DO NOT WRITE IN THIS AREA

DO NOT WRITE IN THIS AREA

5 In a company, the ratio of the number of men to the number of women is 3 : 2

40% of the men are under the age of 25

10% of the women are under the age of 25

What percentage of all the people in the company are under the age of 25?

.....%

**(Total for Question 5 is 4 marks)**

- 6 The plan, front elevation and side elevation of a solid prism are drawn on a centimetre grid.

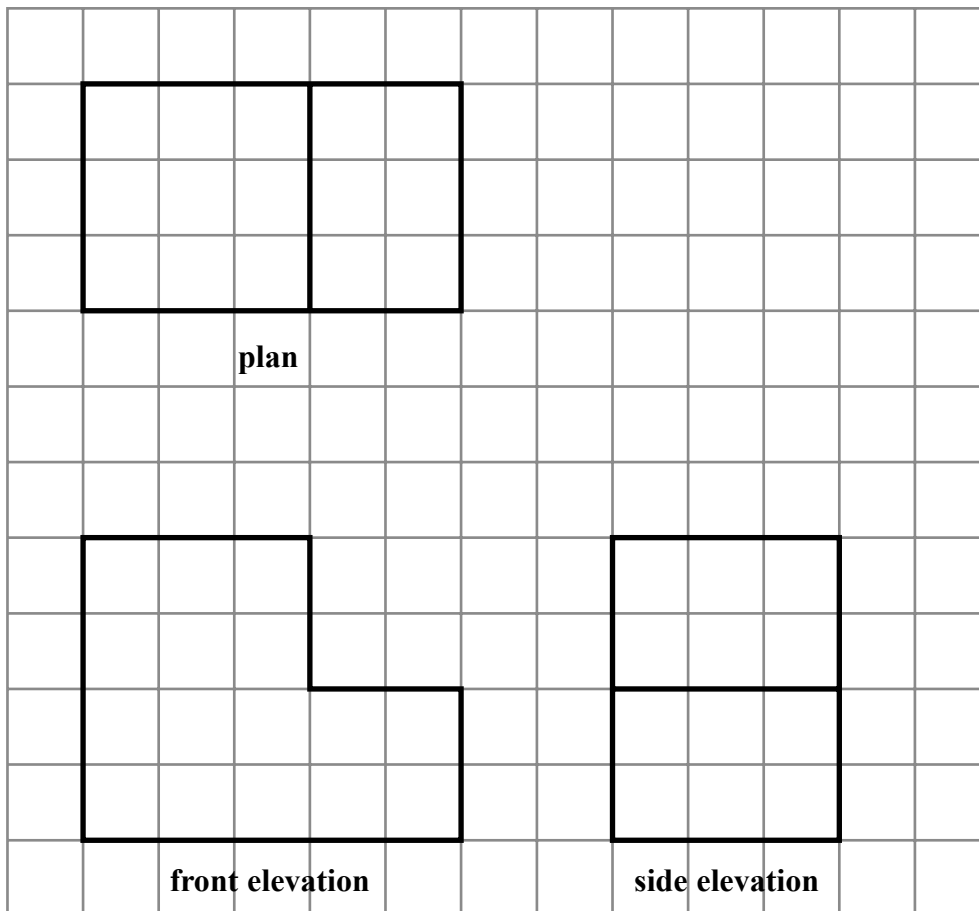

DO NOT WRITE IN THIS AREA

DO NOT WRITE IN THIS AREA

DO NOT WRITE IN THIS AREA

In the space below, draw a sketch of the solid prism.  
Write the dimensions of the prism on your sketch.

(Total for Question 6 is 2 marks)

DO NOT WRITE IN THIS AREA

DO NOT WRITE IN THIS AREA

DO NOT WRITE IN THIS AREA

7 There are 1200 students at a school.

Kate is helping to organise a party.  
She is going to order pizza.

Kate takes a sample of 60 of the students at the school.  
She asks each student to tell her **one** type of pizza they want.

The table shows information about her results.

Pizza	Number of students
ham	20
salami	15
vegetarian	8
margarita	17

Work out how much ham pizza Kate should order.

Write down any assumption you make **and** explain how this could affect your answer.

.....

.....

**(Total for Question 7 is 3 marks)**

8 Here is a parallelogram.

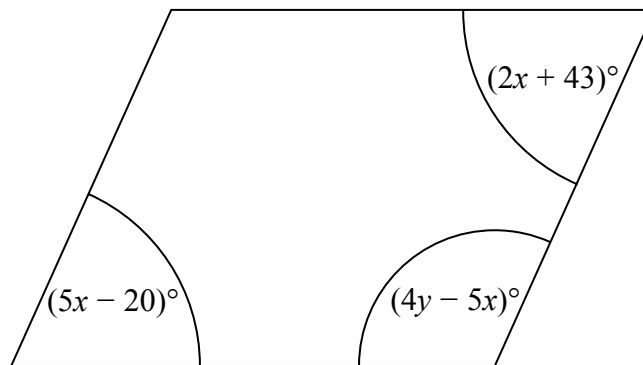

Work out the value of  $x$  and the value of  $y$ .

$$x = \dots\dots\dots$$

$$y = \dots\dots\dots$$

**(Total for Question 8 is 5 marks)**

DO NOT WRITE IN THIS AREA

DO NOT WRITE IN THIS AREA

DO NOT WRITE IN THIS AREA

- 9 Work out the value of  $(9 \times 10^{-4}) \times (3 \times 10^7)$   
Give your answer in standard form.

.....

(Total for Question 9 is 2 marks)

---

- 10 (a) Write down the value of  $64^{\frac{1}{2}}$

.....

(1)

- (b) Find the value of  $\left(\frac{8}{125}\right)^{-\frac{2}{3}}$

.....

(2)

(Total for Question 10 is 3 marks)

---

11 One uranium atom has a mass of  $3.95 \times 10^{-22}$  grams.

(a) Work out an estimate for the number of uranium atoms in 1 kg of uranium.

.....  
(3)

(b) Is your answer to (a) an underestimate or an overestimate?  
Give a reason for your answer.

.....  
.....  
(1)

**(Total for Question 11 is 4 marks)**

DO NOT WRITE IN THIS AREA

DO NOT WRITE IN THIS AREA

DO NOT WRITE IN THIS AREA

DO NOT WRITE IN THIS AREA

DO NOT WRITE IN THIS AREA

DO NOT WRITE IN THIS AREA

12 Pressure =  $\frac{\text{force}}{\text{area}}$

Find the pressure exerted by a force of 900 newtons on an area of 60 cm<sup>2</sup>.  
Give your answer in newtons/m<sup>2</sup>.

..... newtons/m<sup>2</sup>

**(Total for Question 12 is 2 marks)**

13 Rectangle *ABCD* is mathematically similar to rectangle *DAEF*.

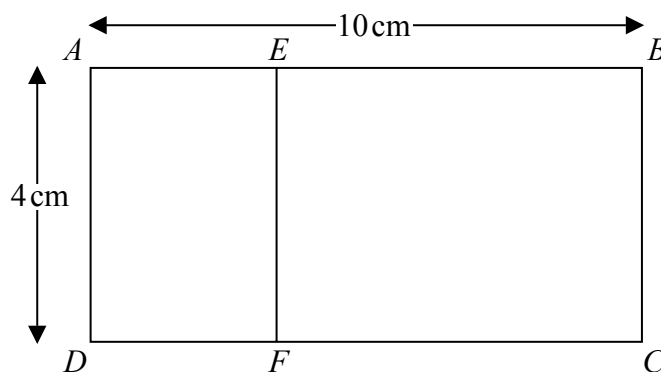

*AB* = 10 cm.  
*AD* = 4 cm.

Work out the area of rectangle *DAEF*.

..... cm<sup>2</sup>

**(Total for Question 13 is 3 marks)**

14 Ben played 15 games of basketball.  
Here are the points he scored in each game.

17 18 18 18 19 20 20 22 23 23 23 26 27 28 28

(a) Draw a box plot for this information.

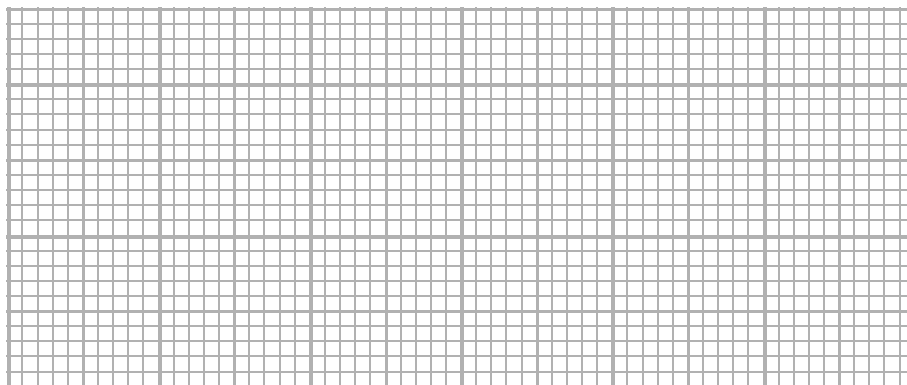

(3)

Sam plays in the same 15 games of basketball.

The median number of points Sam scored is 23

The interquartile range of these points is 12

The range of these points is 20

(b) Who is more consistent at scoring points, Sam or Ben?

You must give a reason for your answer.

(2)

**(Total for Question 14 is 5 marks)**



15 In a shop, all normal prices are reduced by 20% to give the sale price.

The sale price of a TV set is then reduced by 30%.

Mary says,

“ $30 + 20 = 50$ , so this means that the normal price of the TV set has been reduced by 50%.”

Is Mary right?

You must give a reason for your answer.

.....

.....

.....

(Total for Question 15 is 2 marks)

16 Factorise fully  $20x^2 - 5$

.....

(Total for Question 16 is 2 marks)

17 Make  $a$  the subject of  $a + 3 = \frac{2a + 7}{r}$

.....

(Total for Question 17 is 3 marks)

**18** Solid **A** and solid **B** are mathematically similar.

The ratio of the surface area of solid **A** to the surface area of solid **B** is 4:9

The volume of solid **B** is  $405 \text{ cm}^3$ .

Show that the volume of solid **A** is  $120 \text{ cm}^3$ .

---

(Total for Question 18 is 3 marks)

**19** Solve  $x^2 > 3x + 4$

---

(Total for Question 19 is 3 marks)

DO NOT WRITE IN THIS AREA

DO NOT WRITE IN THIS AREA

DO NOT WRITE IN THIS AREA

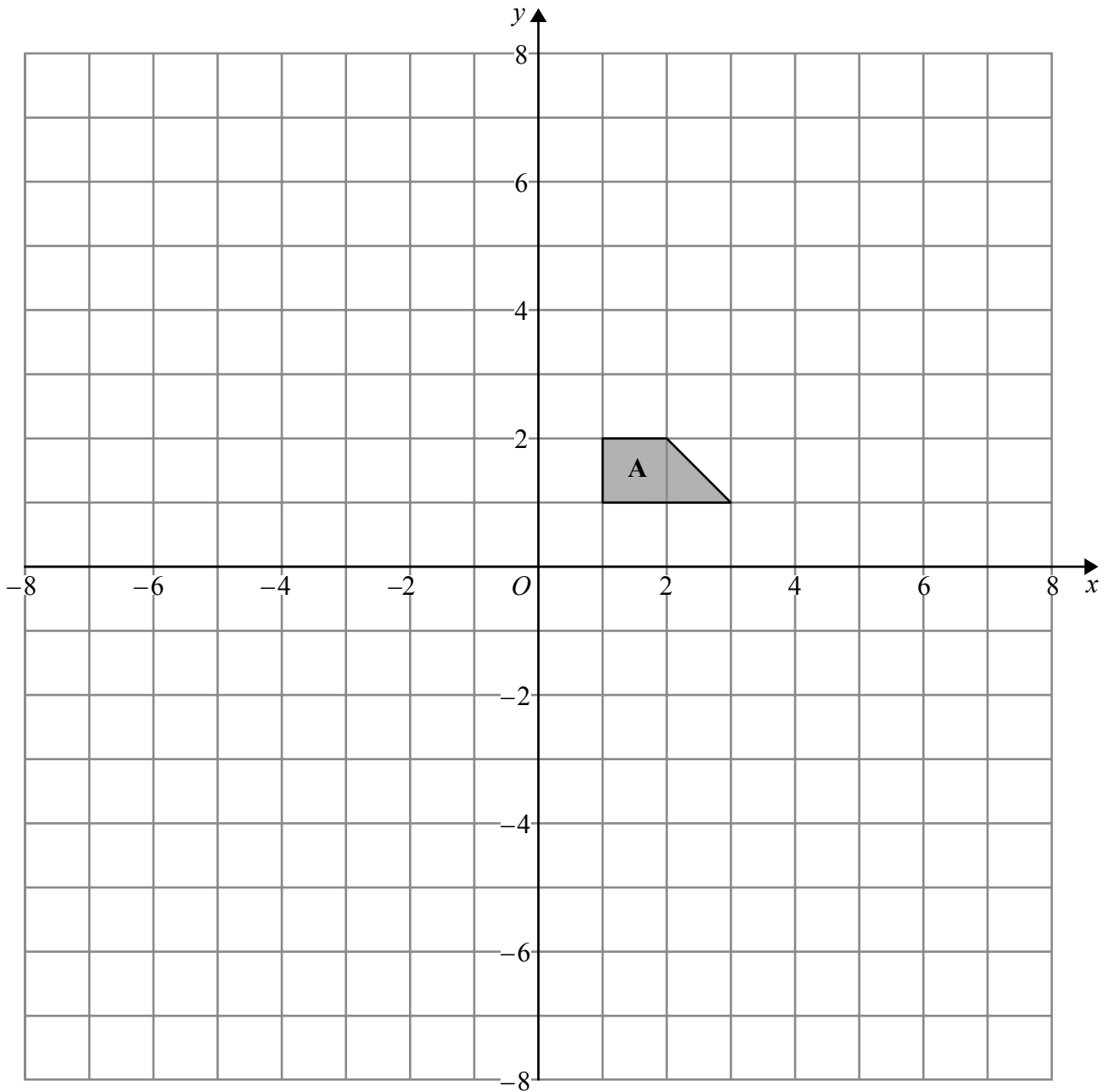

- (a) Enlarge shape **A** by scale factor  $-2$ , centre  $(0, 0)$   
Label your image **B**.

(2)

- (b) Describe fully the single transformation that will map shape **B** onto shape **A**.

(1)

(Total for Question 20 is 3 marks)

21 Here is a speed-time graph for a car journey.  
The journey took 100 seconds.

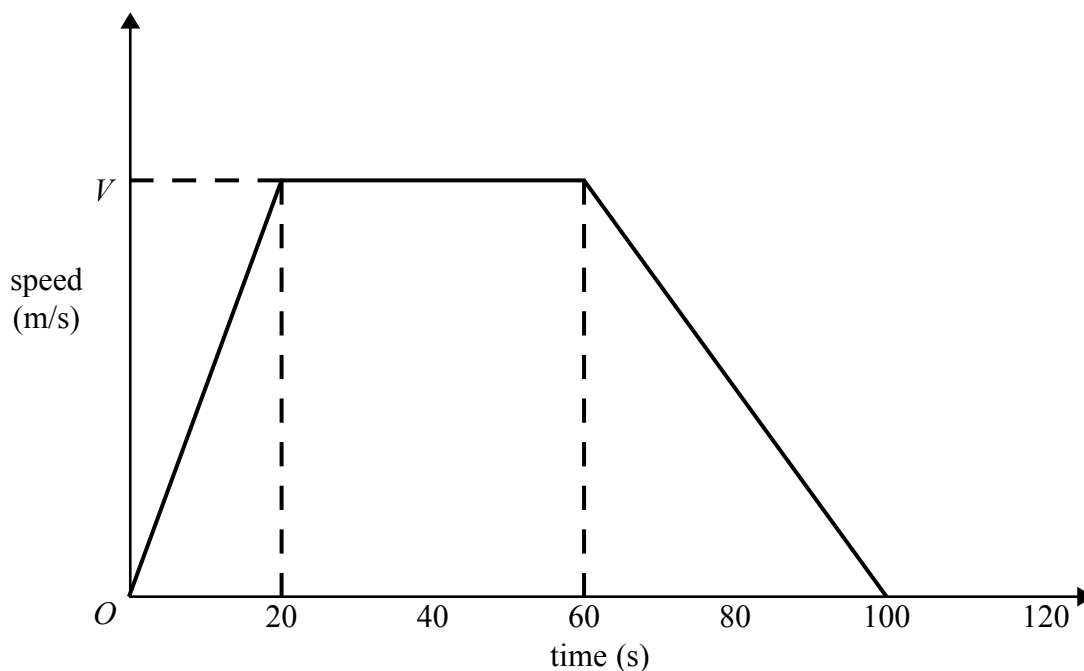

The car travelled 1.75 km in the 100 seconds.

(a) Work out the value of  $V$ .

.....  
(3)

(b) Describe the acceleration of the car for each part of this journey.

.....  
.....  
.....  
.....  
(2)

(Total for Question 21 is 5 marks)

DO NOT WRITE IN THIS AREA

22 Bhavna recorded the lengths of time, in hours, that some adults watched TV last week.

The table shows information about her results.

Length of time ( $t$ hours)	Frequency
$0 \leq t < 10$	6
$10 \leq t < 15$	8
$15 \leq t < 20$	15
$20 \leq t < 40$	5

Bhavna made some mistakes when she drew a histogram for this information.

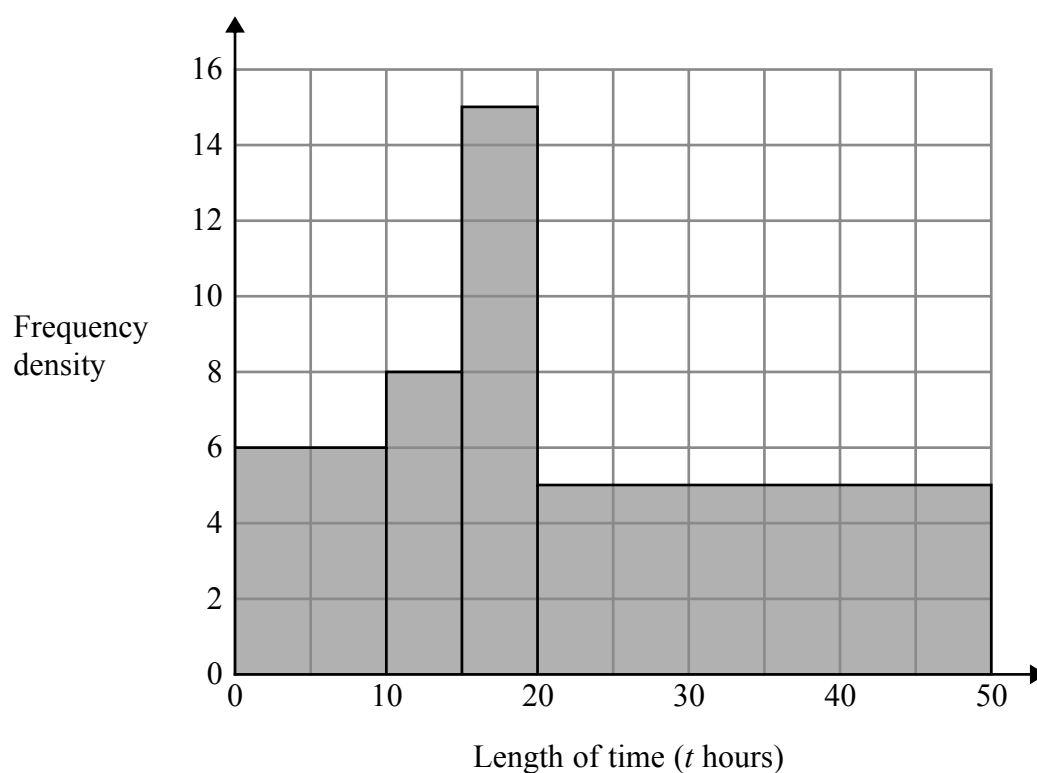

Write down **two** mistakes Bhavna made.

- 1 .....
- .....
- 2 .....
- .....

(Total for Question 22 is 2 marks)

DO NOT WRITE IN THIS AREA

DO NOT WRITE IN THIS AREA

23 Show that  $\frac{1}{1 + \frac{1}{\sqrt{2}}}$  can be written as  $2 - \sqrt{2}$

(Total for Question 23 is 3 marks)

DO NOT WRITE IN THIS AREA

DO NOT WRITE IN THIS AREA

DO NOT WRITE IN THIS AREA

DO NOT WRITE IN THIS AREA

DO NOT WRITE IN THIS AREA

DO NOT WRITE IN THIS AREA

24 John has an empty box.

He puts some red counters and some blue counters into the box.

The ratio of the number of red counters to the number of blue counters is 1 : 4

Linda takes at random 2 counters from the box.

The probability that she takes 2 red counters is  $\frac{6}{155}$

How many red counters did John put into the box?

.....  
**(Total for Question 24 is 4 marks)**

- 25  $A(-2, 1)$ ,  $B(6, 5)$  and  $C(4, k)$  are the vertices of a right-angled triangle  $ABC$ .  
Angle  $ABC$  is the right angle.

Find an equation of the line that passes through  $A$  and  $C$ .

Give your answer in the form  $ay + bx = c$  where  $a$ ,  $b$  and  $c$  are integers.

.....  
(Total for Question 25 is 5 marks)

---

**TOTAL FOR PAPER IS 80 MARKS**

DO NOT WRITE IN THIS AREA

DO NOT WRITE IN THIS AREA

DO NOT WRITE IN THIS AREA



Paper 1MA1: 1H			
Question	Working	Answer	Notes
1		32.968	M1 for correct method (condone one error) A1 for digits 32968 A1 ft (dep M1) for correct placement of decimal pt
2		$m^2 + 10m + 21$	M1 for at least 3 terms out of a maximum of 4 correct from expansion A1
3		152	M1 Start to method $ABD = 38^\circ$ <b>and</b> $BAD$ or $DBC$ or $DCB = 38^\circ$ M1 $ADB$ or $BDC = 180 - 2 \times 38 (=104)$ A1 for 152 with working
4 (a)		48	P1 start to process eg. $3 \times 80 (=240)$ P1 '240' $\div 5$ A1
(b)			C1 eg. she may drive a different distance and therefore her average speed could be different

Paper 1MA1: 1H			
Question	Working	Answer	Notes
5		28	<p>P1 Process to start to solve problem eg. <math>\frac{3}{5} \times 40</math> or divide any number in the ratio 3:2</p> <p>P1 Second step in process to solve problem eg. <math>\frac{2}{5} \times 10</math> or find number of males/females under 25 for candidate's chosen number</p> <p>P1 for complete process</p> <p>A1</p>
6		Correct sketch	<p>C1 interprets diagram eg. draw a solid shape with at least two correct dimensions</p> <p>C1 draws correct prism with all necessary dimensions.</p>
7		400	<p>P1 Start to process eg. <math>1200 \div 60</math></p> <p>A1 400 oe (accept number of whole pizzas eg. <math>400 \div 4 = 100</math> with 4 people per pizza)</p> <p>C1 Eg. Assumption that sample is representative of population – it may not be all 1200 people are going to the party – need less pizza if they don't, assume 4 people per pizza – if different may need more/fewer pizzas</p>

Paper 1MA1: 1H			
Question	Working	Answer	Notes
8		$x = 21, y = 50$	P1 process to start solving problem eg. form an appropriate equation P1 complete process to isolate terms in $x$ A1 for $x = 21$ P1 complete process to find second variable A1 $y = 50$
9		$2.7 \times 10^4$	M1 For evidence of a correct method eg. $27 \times 10^{-4+7}$ A1
10 (a)		8	B1
(b)		$\frac{25}{4}$ oe	M1 for correct first step A1
11 (a)		$2.5 \times 10^{24}$	P1 process to estimate or divide P1 a complete process eg. $(1 \times 10^3) \div (4 \times 10^{-22})$ A1
(b)		Under-estimate	C1 ft from (i) Eg. under estimate as number rounded up but in denominator of fraction

Paper 1MA1: 1H			
Question	Working	Answer	Notes
12		150 000	M1 $60 \div 100^2$ or $900 \div 60$ or $900 \div "60"$ A1
13		6.4	P1 Start to process eg. find scale factor (0.4) or $\frac{AE}{4} = \frac{4}{10}$ P1 Complete process to find area A1
14 (a)	Median = 22; lq = 18; uq = 26	Box plot	C1 Start to interpret information eg. one of median, lq, uq correct C1 Starts to communicate information eg. box plot with box, whiskers and at least 3 of median, lq, uq, min and max correct C1 Correct box plot
(b)		Ben with reason	M1 interpret information eg ft from box plot to find iqr (8) or range (11) C1 ft eg. Ben with lower iqr (8) and range (11)
15		No with reason	C1 Starts to formulate reason eg. No with partial explanation or $0.8 \times 0.7$ or starts to use figures C1 No with full explanation eg. $0.8 \times 0.7 = 0.56$ so only 44% reduction
16		$5(2x + 1)(2x - 1)$	M1 for $5(4x^2 - 1)$ A1

Paper 1MA1: 1H			
Question	Working	Answer	Notes
17		$a = \frac{7-3r}{r-2}$	M1 Remove fraction and expand brackets M1 Isolate terms in $a$ A1
18		Given result	M1 For length scale factor eg $\sqrt{\frac{4}{9}}$ <b>or</b> 120 : 405 M1 $\left(\sqrt{\frac{4}{9}}\right)^3 \times 405$ <b>or</b> $2^3 : 3^3$ (from 120 : 405) A1 120 from correct arithmetic <b>or</b> conclusion relating $2^3 : 3^3$ with $2^2 : 3^2$ with correct working
19		$x > 4, x < -1$	M1 rearrange quadratic and factorise M1 critical values of 4 and $-1$ found A1
20 (a)		$(-2, -2)(-6, -2)$ $(-2, -4)(-4, -4)$	M1 Shape drawn in correct orientation A1
(b)		Enlargement sf $-0.5$ centre $(0,0)$	C1

Paper 1MA1: 1H			
Question	Working	Answer	Notes
21 (a)		25	C1 For interpretation eg.. area equated to 1750m P1 Process to solve equation A1
(b)		Description	C1 Start to interpret graph eg. describe or give acceleration for one stage of the journey or state that acceleration is constant in all 3 parts C1 Describe acceleration for all stages of the journey or give acceleration for all 3 stages (1.25 m/s <sup>2</sup> ; 0 m/s <sup>2</sup> ; -0.625 m/s <sup>2</sup> )
22			C1 C1 for frequencies used for heights or areas not proportional to frequencies C1 C1 for 2 <sup>nd</sup> mistake - final bar of wrong width
23		Given result	C1 Correct first step towards simplifying expression eg. $\frac{\sqrt{2}}{\sqrt{2} + 1}$ C1 Correct step to rationalise denominator C1 Conclusion to given result

Paper 1MA1: 1H			
Question	Working	Answer	Notes
24		25	<p>P1 For process to start to solve. Eg use of <math>x</math> and <math>4x</math> or <math>x/5x</math> and <math>4x/5x</math></p> <p>P1 process to form equation eg <math>\frac{x}{5x} \times \frac{x-1}{5x-1} = \frac{6}{155}</math></p> <p>P1 Processes to eliminate fractions and reduce equation to linear form eg. <math>155x - 155 = 150x - 30</math></p> <p>A1</p>
25		$3y - 4x = 11$	<p>P1 process to start to solve problem eg. draw a diagram, find gradient of <math>AB</math> (0.5)</p> <p>P1 process to use gradients eg. find gradient of <math>BC</math> (-2)</p> <p>P1 Process to find <math>y</math> coordinate of <math>C</math> (9)</p> <p>P1 Process to find equation of <math>AC</math></p> <p>A1</p>





Write your name here

Surname

Other names

**Pearson Edexcel**  
**Level 1/Level 2 GCSE (9 - 1)**

Centre Number

--	--	--	--	--

Candidate Number

--	--	--	--

# Mathematics

## Paper 2 (Calculator)

**Higher Tier**

Sample Assessment Materials – Issue 2

**Time: 1 hour 30 minutes**

Paper Reference

**1MA1/2H**

**You must have:** Ruler graduated in centimetres and millimetres, protractor, pair of compasses, pen, HB pencil, eraser, calculator.

Total Marks

### Instructions

- Use **black** ink or ball-point pen.
- **Fill in the boxes** at the top of this page with your name, centre number and candidate number.
- Answer **all** questions.
- Answer the questions in the spaces provided – *there may be more space than you need.*
- **Calculators may be used.**
- If your calculator does not have a  $\pi$  button, take the value of  $\pi$  to be 3.142 unless the question instructs otherwise.
- Diagrams are **NOT** accurately drawn, unless otherwise indicated.
- You must **show all your working out.**



### Information

- The total mark for this paper is 80
- The marks for **each** question are shown in brackets – *use this as a guide as to how much time to spend on each question.*

### Advice

- Read each question carefully before you start to answer it.
- Keep an eye on the time.
- Try to answer every question.
- Check your answers if you have time at the end.

Turn over ►

S48574A

©2015 Pearson Education Ltd.

6/4/17/17/14/6/6/6/



**PEARSON**

Answer ALL questions.

Write your answers in the spaces provided.

You must write down all the stages in your working.

- 1 Frank, Mary and Seth shared some sweets in the ratio 4 : 5 : 7  
Seth got 18 more sweets than Frank.

Work out the total number of sweets they shared.

(Total for Question 1 is 3 marks)

- 2  $PQR$  is a right-angled triangle.

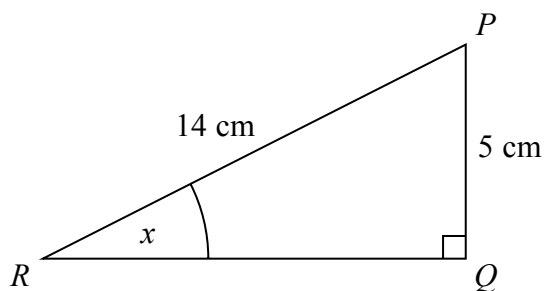

Work out the size of the angle marked  $x$ .  
Give your answer correct to 1 decimal place.

(Total for Question 2 is 2 marks)

3 Here are the first four terms of an arithmetic sequence.

6      10      14      18

(a) Write an expression, in terms of  $n$ , for the  $n$ th term of this sequence.

.....  
(2)

The  $n$ th term of a different arithmetic sequence is  $3n + 5$

(b) Is 108 a term of this sequence?  
Show how you get your answer.

(2)

**(Total for Question 3 is 4 marks)**

---

4 Axel and Lethna are driving along a motorway.

They see a road sign.

The road sign shows the distance to Junction 8

It also shows the average time drivers take to get to Junction 8

To Junction 8 30 miles 26 minutes
---

The speed limit on the motorway is 70 mph.

Lethna says

“We will have to drive faster than the speed limit to drive 30 miles in 26 minutes.”

Is Lethna right?

You must show how you get your answer.

---

(Total for Question 4 is 3 marks)

DO NOT WRITE IN THIS AREA

DO NOT WRITE IN THIS AREA

DO NOT WRITE IN THIS AREA

DO NOT WRITE IN THIS AREA

DO NOT WRITE IN THIS AREA

DO NOT WRITE IN THIS AREA

5 The table shows some information about the foot lengths of 40 adults.

Foot length ( $f$ cm)	Number of adults
$16 \leq f < 18$	3
$18 \leq f < 20$	6
$20 \leq f < 22$	10
$22 \leq f < 24$	12
$24 \leq f < 26$	9

(a) Write down the modal class interval.

.....  
(1)

(b) Calculate an estimate for the mean foot length.

..... cm  
(3)

**(Total for Question 5 is 4 marks)**

6 Triangles  $ABD$  and  $BCD$  are right-angled triangles.

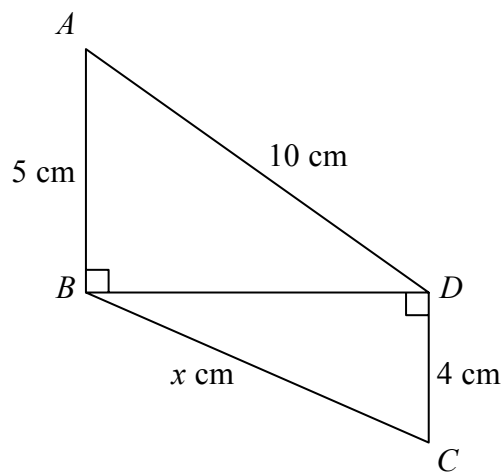

Work out the value of  $x$ .  
Give your answer correct to 2 decimal places.

(Total for Question 6 is 4 marks)

DO NOT WRITE IN THIS AREA

DO NOT WRITE IN THIS AREA

DO NOT WRITE IN THIS AREA

DO NOT WRITE IN THIS AREA

DO NOT WRITE IN THIS AREA

DO NOT WRITE IN THIS AREA

7 The graph of  $y = f(x)$  is drawn on the grid.

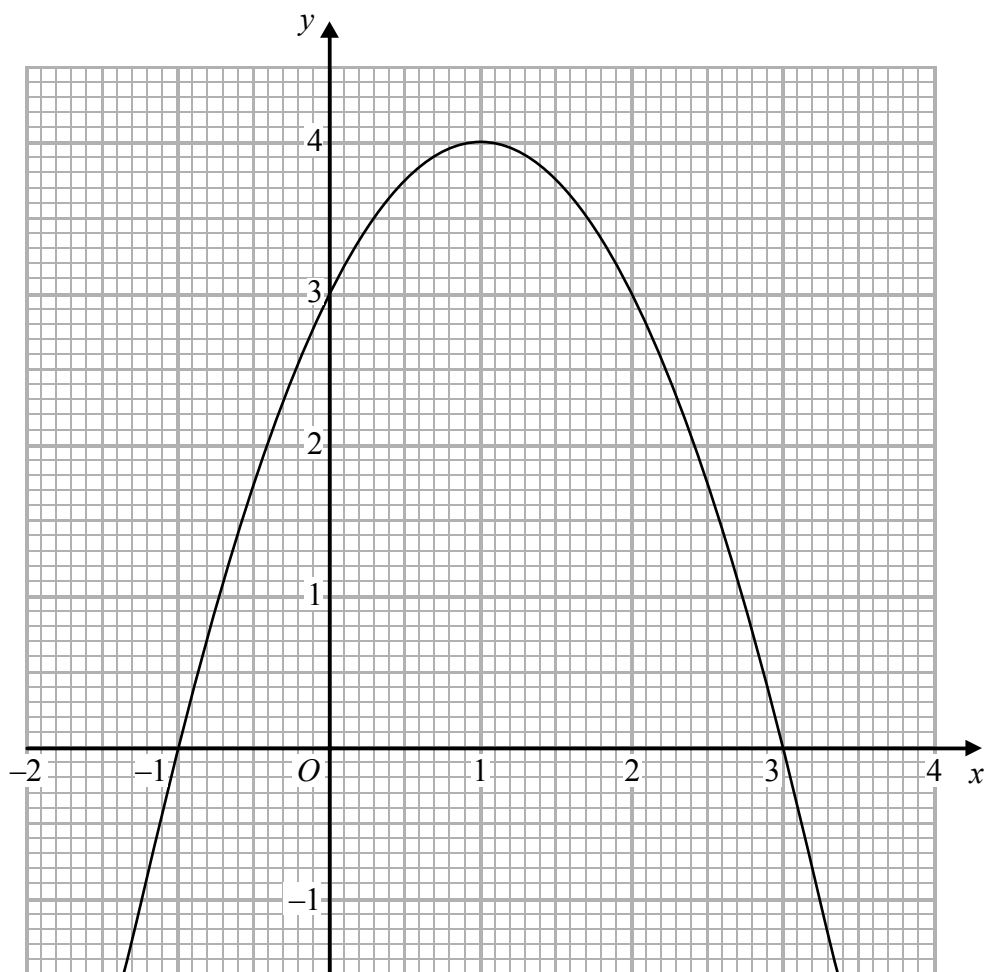

(a) Write down the coordinates of the turning point of the graph.

(....., .....)  
(1)

(b) Write down the roots of  $f(x) = 2$

.....  
(1)

(c) Write down the value of  $f(0.5)$

.....  
(1)

**(Total for Question 7 is 3 marks)**

8 In a box of pens, there are

three times as many red pens as green pens  
**and** two times as many green pens as blue pens.

For the pens in the box, write down  
the ratio of the number of red pens to the number of green pens to the number of blue pens.

.....  
(Total for Question 8 is 2 marks)

DO NOT WRITE IN THIS AREA

DO NOT WRITE IN THIS AREA

DO NOT WRITE IN THIS AREA



DO NOT WRITE IN THIS AREA

DO NOT WRITE IN THIS AREA

DO NOT WRITE IN THIS AREA

- 9  $ABCD$  is a rectangle.  
 $EFGH$  is a trapezium.

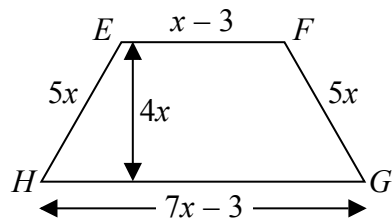
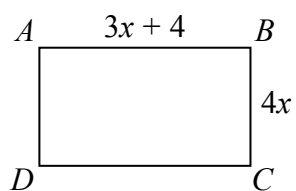

All measurements are in centimetres.  
The perimeters of these two shapes are the same.

Work out the area of the rectangle.

.....  $\text{cm}^2$

**(Total for Question 9 is 5 marks)**

10 Katy invests £2000 in a savings account for 3 years.

The account pays compound interest at an annual rate of

2.5% for the first year

$x\%$  for the second year

$x\%$  for the third year

There is a total amount of £2124.46 in the savings account at the end of 3 years.

(a) Work out the rate of interest in the second year.

.....  
(4)

Katy goes to work by train.

The cost of her weekly train ticket increases by 12.5% to £225

(b) Work out the cost of her weekly train ticket before this increase.

£.....  
(2)

**(Total for Question 10 is 6 marks)**

11

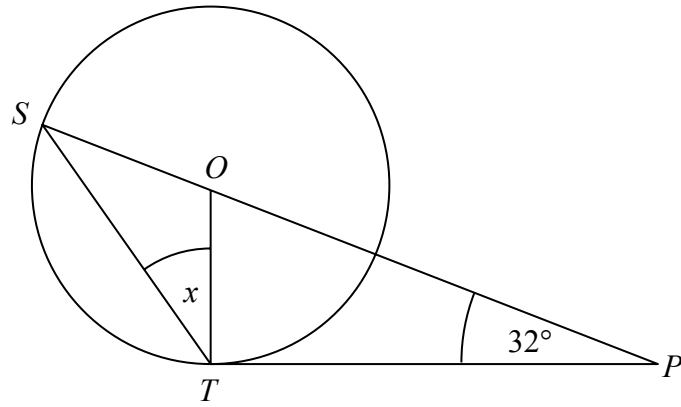

$S$  and  $T$  are points on the circumference of a circle, centre  $O$ .  
 $PT$  is a tangent to the circle.  
 $SOP$  is a straight line.  
Angle  $OPT = 32^\circ$

Work out the size of the angle marked  $x$ .  
You must give a reason for each stage of your working.

(Total for Question 11 is 4 marks)

12 A and B are two sets of traffic lights on a road.

The probability that a car is stopped by lights A is 0.4

If a car is stopped by lights A, then the probability that the car is **not** stopped by lights B is 0.7

If a car is **not** stopped by lights A, then the probability that the car is **not** stopped by lights B is 0.2

(a) Complete the probability tree diagram for this information.

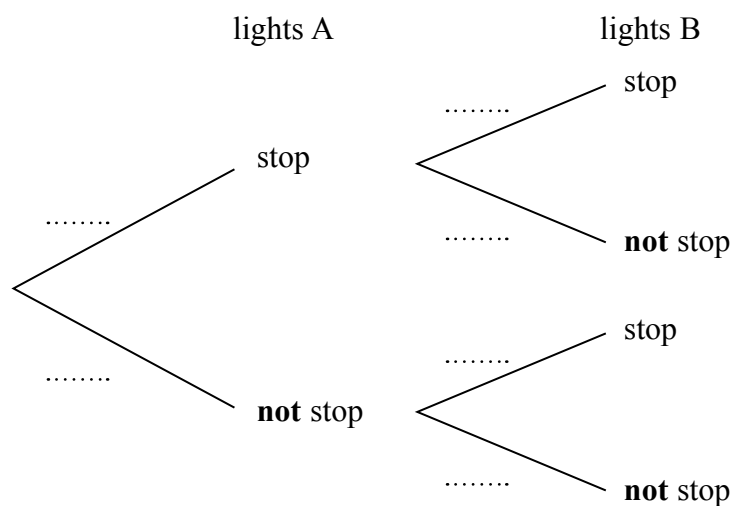

(2)

Mark drove along this road.

He was stopped by just one of the sets of traffic lights.

(b) Is it more likely that he was stopped by lights A or by lights B?

You must show your working.

(3)

(Total for Question 12 is 5 marks)

DO NOT WRITE IN THIS AREA

DO NOT WRITE IN THIS AREA

DO NOT WRITE IN THIS AREA

13  $d$  is inversely proportional to  $c$

When  $c = 280$ ,  $d = 25$

Find the value of  $d$  when  $c = 350$

$d = \dots\dots\dots$

**(Total for Question 13 is 3 marks)**

---

14 Prove algebraically that

$(2n + 1)^2 - (2n + 1)$  is an even number

for all positive integer values of  $n$ .

**(Total for Question 14 is 3 marks)**

---

15 Prove algebraically that the recurring decimal  $0.2\dot{5}$  has the value  $\frac{23}{90}$

(Total for Question 15 is 2 marks)

16 Show that  $\frac{1}{6x^2 + 7x - 5} \div \frac{1}{4x^2 - 1}$  simplifies to  $\frac{ax + b}{cx + d}$  where  $a, b, c$  and  $d$  are integers.

(Total for Question 16 is 3 marks)

DO NOT WRITE IN THIS AREA

DO NOT WRITE IN THIS AREA

DO NOT WRITE IN THIS AREA

DO NOT WRITE IN THIS AREA

DO NOT WRITE IN THIS AREA

DO NOT WRITE IN THIS AREA

17 The diagram shows a sector of a circle of radius 7 cm.

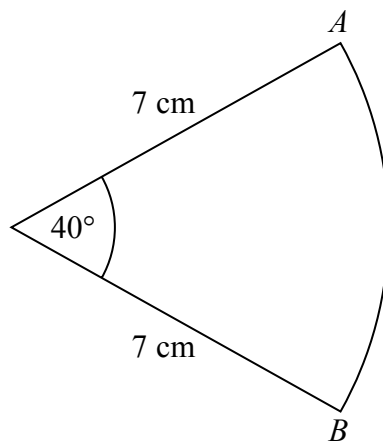

Work out the length of arc  $AB$ .  
Give your answer correct to 3 significant figures.

..... cm

**(Total for Question 17 is 2 marks)**

18  $m = \frac{\sqrt{s}}{t}$   $s = 3.47$  correct to 3 significant figures  
 $t = 8.132$  correct to 4 significant figures

By considering bounds, work out the value of  $m$  to a suitable degree of accuracy.  
Give a reason for your answer.

(Total for Question 18 is 5 marks)

DO NOT WRITE IN THIS AREA

DO NOT WRITE IN THIS AREA

DO NOT WRITE IN THIS AREA



DO NOT WRITE IN THIS AREA

DO NOT WRITE IN THIS AREA

DO NOT WRITE IN THIS AREA

19 The graph of  $y = f(x)$  is shown on both grids below.

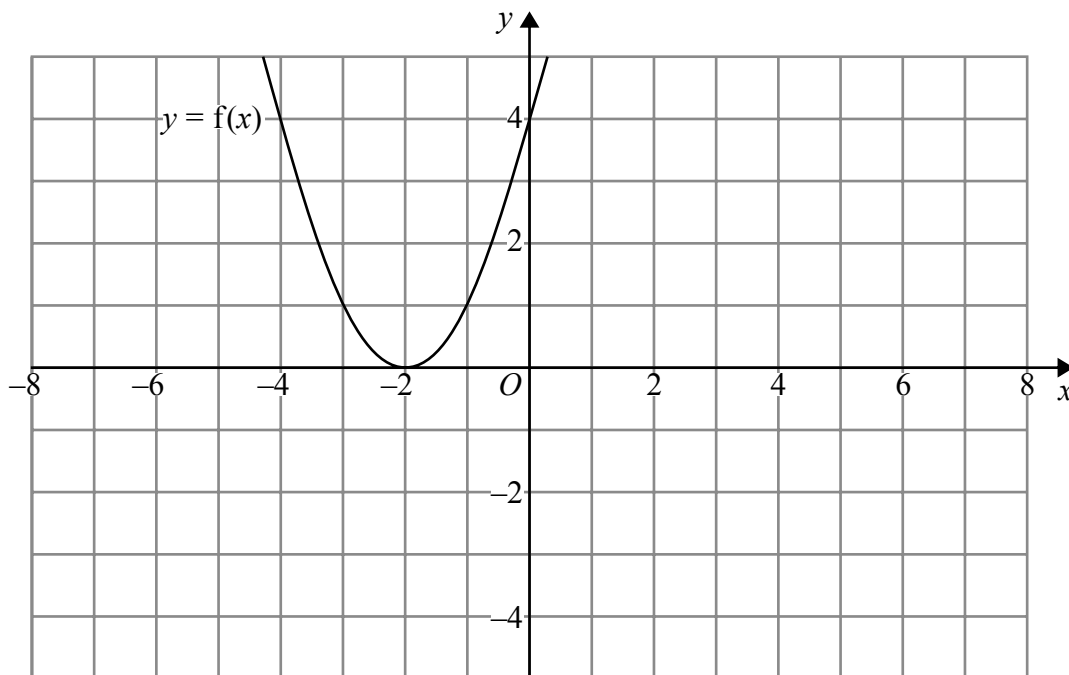

(a) On the grid above, sketch the graph of  $y = f(-x)$

(1)

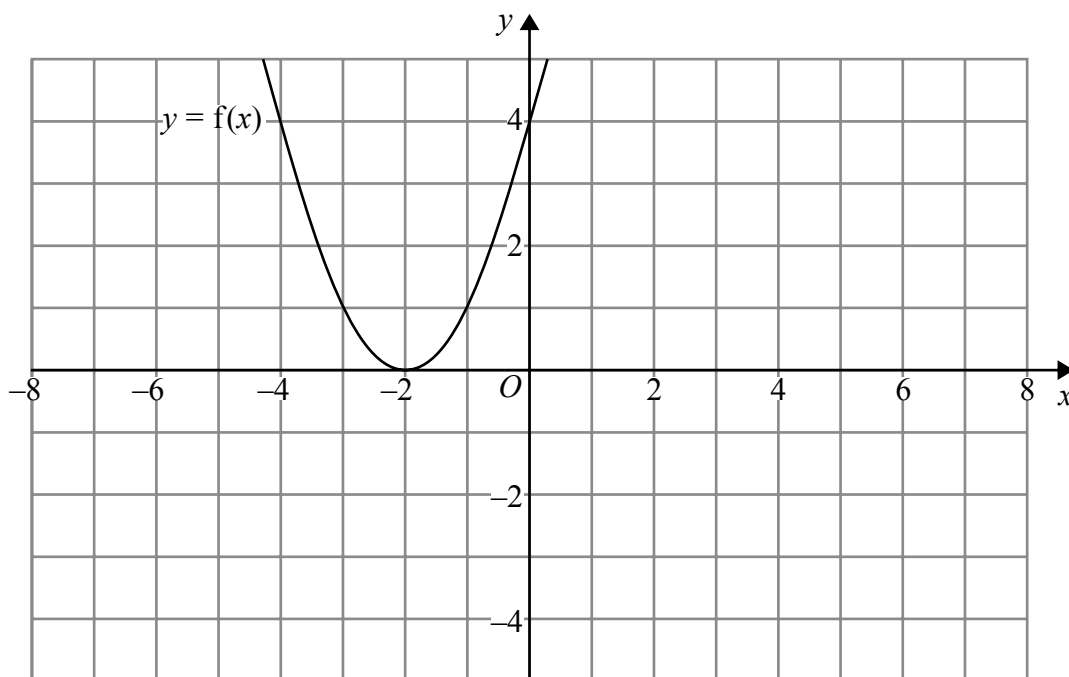

(b) On this grid, sketch the graph of  $y = -f(x) + 3$

(1)

(Total for Question 19 is 2 marks)

20 Solve algebraically the simultaneous equations

$$x^2 + y^2 = 25$$

$$y - 2x = 5$$

DO NOT WRITE IN THIS AREA

DO NOT WRITE IN THIS AREA

DO NOT WRITE IN THIS AREA

(Total for Question 20 is 5 marks)

DO NOT WRITE IN THIS AREA

DO NOT WRITE IN THIS AREA

DO NOT WRITE IN THIS AREA

21 In triangle  $RPQ$ ,

$$RP = 8.7 \text{ cm}$$

$$PQ = 5.2 \text{ cm}$$

$$\text{Angle } PRQ = 32^\circ$$

- (a) Assuming that angle  $PQR$  is an acute angle, calculate the area of triangle  $RPQ$ .  
Give your answer correct to 3 significant figures.

.....cm<sup>2</sup>  
(4)

- (b) If you did not know that angle  $PQR$  is an acute angle, what effect would this have on your calculation of the area of triangle  $RPQ$ ?

.....  
.....  
.....  
(1)

**(Total for Question 21 is 5 marks)**

22 A frustum is made by removing a small cone from a large cone as shown in the diagram.

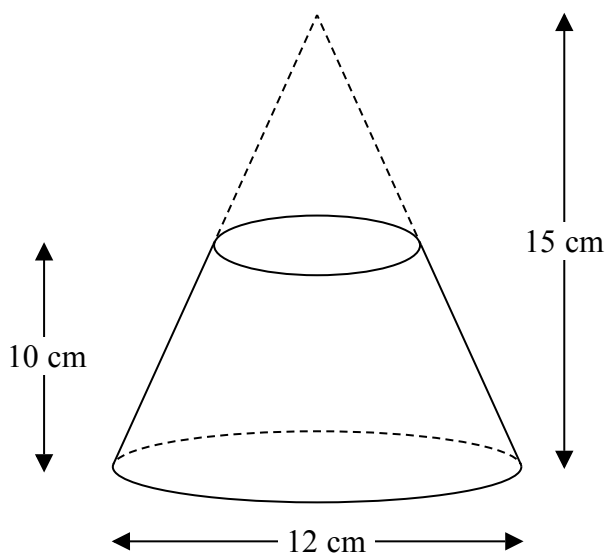

Volume of cone =  $\frac{1}{3}\pi r^2 h$

The frustum is made from glass.  
The glass has a density of  $2.5 \text{ g/cm}^3$

Work out the mass of the frustum.  
Give your answer to an appropriate degree of accuracy.

89

(Total for Question 22 is 5 marks)

**TOTAL FOR PAPER IS 80 MARKS**

Paper 1MA1: 2H					
Question	Working	Answer	Notes		
1		96	P1	a strategy to start to solve the problem eg $18 \div (7 - 4) (=6)$	
			P1	for completing the process of solution eg “6” $\times (4 + 5 + 7)$	
			A1	cao	
2		20.9	M1	correct recall of appropriate formula eg $\sin x = \frac{5}{14}$	
			A1	for 20.9(248...)	
3 (a)		$4n+2$	M	start to deduce nth term from information given eg $4n+k$ where $k \neq 2$	
			A1	cao	
(b)		No (supported)	M1	starts method that could lead to a deduction eg uses inverse operations	
			C1	for a convincing argument eg 34 is 107 so NO; $(108-5) \div 3$ is not an integer	
4		conclusion  (supported)	P1	$30 \div 70 (=0.428)$	$26 \div 60 (=0.4333\dots)$
			P1	$60 \times “0.428\dots”$	$70 \times “0.4333\dots”$
			C1	for conclusion linked to 25.7 mins, 30.3 miles or 69.2 mph	
				$30 \div 26 (=1.153\dots)$	
				$60 \times “1.153\dots”$	

Paper 1MA1: 2H			
Question	Working	Answer	Notes
5 (a)		$22 \leq f < 24$	B1
(b)		21.9	M1 $x \times f$ using midpoints M1 (dep on previous mark) " $x \times f$ " $\div 40$ A1 accept 22 if working seen
6		9.54	P1 $10^2 - 5^2 (=75)$ P1 "75" + $4^2 (=91)$ P1 $\sqrt{(10^2 - 5^2 + 4^2)}$ A1 9.53 – 9.54
7 (a)		(1, 4)	B1
(b)		-0.4, 2.4	B1
(c)		3.75	B1 accept 3.7 – 3.8
8		6 : 2 : 1	M1 for correct interpretation of any one statement eg. 3 : 1; 1 : 0.5 A1 accept any equivalent ratio eg. 3 : 1 : 0.5

Paper 1MA1: 2H			
Question	Working	Answer	Notes
9		203	<p>P1 translate into algebra for rectangle: <math>4x+4x+3x+4+3x+4</math> (<math>=14x+8</math>) or for trapezium: <math>5x+5x+x-3+7x-3</math> (<math>=18x-6</math>)</p> <p>P1 equating: eg <math>18x-6=14x+8</math> (<math>4x=14</math>)</p> <p>A1 solving for <math>x</math>: <math>x=14/4 = 3.5</math> oe</p> <p>P1 process to find area: “3.5” <math>\times</math> 3+4 (ft) or “3.5” <math>\times</math> 4 ft</p> <p>A1 cao</p>
10 (a)		1.8%	<p>P1 for start to process eg. <math>2000 \times 1.025</math> (<math>=2050</math>)</p> <p>P1 for process to use all given information eg “2050” <math>\times m^2 = 2124.46</math>  or “2050” <math>\times \left(1 + \frac{x}{100}\right)^2 = 2124.46</math></p> <p>P1 for process to find their unknown eg <math>m = \sqrt{\frac{2124.46}{2050}}</math> (<math>=1.01799\dots</math>)</p> <p>A1 for 1.79% – 1.8 %</p>
(b)		200	<p>M1 <math>225 \div 1.125</math> oe</p> <p>A1</p>

Paper 1MA1: 2H			
Question	Working	Answer	Notes
11		29°	<p>C1 angle <math>OTP = 90^\circ</math>, quoted or shown on the diagram</p> <p>M1 method that leads to <math>180 - (90 + 32)</math> or 58 shown at <i>TOP</i> OR that leads to 122 shown at <i>SOT</i></p> <p>M1 complete method leading to <math>“58” \div 2</math> or <math>(180 - “122”) \div 2</math> or 29 shown at <i>TSP</i></p> <p>C1 for angle of <math>29^\circ</math> clearly indicated and appropriate reasons linked to method eg angle between <u>radius</u> and <u>tangent</u> = <math>90^\circ</math> and sum of <u>angles</u> in a <u>triangle</u> = <math>180^\circ</math>; <u>ext angle</u> of a triangle <u>equal</u> to sum of <u>int opp angles</u> and base <u>angles</u> of an <u>isos triangle</u> are <u>equal</u> or <u>angle at centre</u> = <math>2 \times</math> <u>angle at circumference</u> or <u>ext angle</u> of a triangle <u>equal</u> to sum of <u>int opp angles</u></p>
12	(a)	0.4,0.6	B1 correctly placing probs for light A eg 0.4, 0.6
	(b)	0.3,0.7,0.8,0.2 B with correct probabilities	<p>B1 correctly placing probs for light B eg 0.3, 0.7, 0.8, 0.2</p> <p>P1 (ft) eg <math>0.4 \times 0.3</math> or <math>0.6 \times 0.8</math> or <math>1 - (0.28 + 0.12)</math></p> <p>P1 both sets of correct probability calculations</p> <p>C1 Correct interpretation of results with correct comparable results</p>
13		20	<p>M1 Establishing method linked to proportion eg <math>d = k \div c</math> or <math>25 = k \div 280</math></p> <p>M1 (dep) substitution eg <math>d = 7000 \div 350</math> or <math>25 \times 280 \div 350</math> oe</p> <p>A1 cao</p>



Paper 1MA1: 2H			
Question	Working	Answer	Notes
14	$\begin{aligned} &(4n^2+2n+2n+1) \\ &\quad - (2n+1) = \\ &4n^2+4n+1-2n-1 \\ &= 4n^2 + 2n \\ &= 2n(2n + 1) \end{aligned}$	proof (supported)	<p>M1 for 3 out of 4 terms correct in the expansion of <math>(2n + 1)^2</math> <b>or</b> <math>(2n + 1)\{(2n + 1) - 1\}</math></p> <p>P1 for <math>4n^2 + 2n</math> or equivalent expression in factorised form</p> <p>C1 for convincing statement using <math>2n(2n + 1)</math> or <math>2(2n^2 + n)</math> or <math>4n^2 + 2n</math> to prove the result</p>
15		$\frac{23}{90}$	<p>M1 For a fully complete method as far as finding two correct decimals that, when subtracted, give a terminating decimal (or integer) and showing intention to subtract eg <math>x = 0.2\dot{5}</math> so <math>10x = 2.5\dot{5}</math> then <math>9x = 2.3</math> leading to...</p> <p>A1 correct working to conclusion</p>
16		$\frac{2x+1}{3x+5}$	<p>M1 for <math>(3x \pm 5)(2x \pm 1)</math> or <math>(2x + 1)(2x - 1)</math></p> <p>M1 <math>\frac{1}{(3x \pm 5)(2x \pm 1)} \times (2x + 1)(2x - 1)</math></p> <p>A1</p>
17		4.89	<p>M1 <math>\frac{40}{360} \times 2 \times \pi \times 7</math> oe</p> <p>A1 4.8 – 4.9</p>

Paper 1MA1: 2H			
Question	Working	Answer	Notes
18		0.229 With Explanation	<p>B1 Finding bound of s: 3.465 or 3.475 or 3.474999... or Finding bound of t: 8.1315 or 8.1325 or 8.132499...</p> <p>P1 Use of “upper bound” and “lower bound” in equation</p> <p>P1 Process of choosing correct bounds eg <math>\frac{\sqrt{3.475}}{8.1315}</math> or <math>\frac{\sqrt{3.465}}{8.1325}</math></p> <p>A1 For 0.2292... and 0.2288.. from correct working</p> <p>C1 For 0.229 from 0.2292.. and 0.2288.. since both LB and UB round to 0.229</p>
19	(a)	Sketch	P1 Parabola passes through all three of the points (0, 4), (2,0), (4, 4)
	(b)	Sketch	P1 Parabola passes through all three of the points (-4, -1), (-2,2), (0, -1)
20		$x=0, y=5$ $x=-4, y=-3$	<p>M1 Initial process of substitution eg <math>x^2 + (2x + 5)^2 (=25)</math></p> <p>M1 for expanding and simplifying eg <math>x^2 + 4x^2 + 10x + 10x + 25 (=25)</math></p> <p>M1 Use of factorisation or correct substitution into quadratic formula or completing the square to solve an equation of the form <math>ax^2 + bx + c = 0, a \neq 0</math></p> <p>A1 correct values of <math>x</math> or <math>y</math></p> <p>C1 <math>x = 0, x = -4, y = 5, y = -3</math> correctly matched <math>x</math> and <math>y</math> values</p>

Paper 1MA1: 2H			
Question	Working	Answer	Notes
21 (a)		130	<p>P1 start to process eg draw a labelled triangle or use of sine rule <math>\frac{\sin Q}{8.7} = \frac{\sin 32}{5.2}</math></p> <p>P1 process to find of <math>Q</math> eg <math>Q = \sin^{-1} \left[ \frac{\sin 32}{5.2} \times 8.7 \right]</math></p> <p>P1 process to find area of triangle <math>PRQ</math>.</p> <p>A1 22.5 – 22.6</p>
(b)			<p>C1 angle <math>PRQ</math> is obtuse so need to find area of two triangles.</p>
22		1361	<p>P1 process using similar triangles to find base of small cone eg. 4 cm used as diameter or 2 cm used as radius</p> <p>P1 process to find volume of one cone</p> <p>P1 complete process to find volume of frustum</p> <p>P1 complete process to find mass or 1360 – 1362</p> <p>A1 1361 or 1360 or 1400</p>



Write your name here

Surname

Other names

**Pearson Edexcel**  
**Level 1/Level 2 GCSE (9 - 1)**

Centre Number

--	--	--	--	--

Candidate Number

--	--	--	--

# Mathematics

## Paper 3 (Calculator)

**Higher Tier**

Sample Assessment Materials – Issue 2

**Time: 1 hour 30 minutes**

Paper Reference

**1MA1/3H**

**You must have:** Ruler graduated in centimetres and millimetres, protractor, pair of compasses, pen, HB pencil, eraser, calculator.

Total Marks

### Instructions

- Use **black** ink or ball-point pen.
- **Fill in the boxes** at the top of this page with your name, centre number and candidate number.
- Answer **all** questions.
- Answer the questions in the spaces provided – *there may be more space than you need.*
- **Calculators may be used.**
- If your calculator does not have a  $\pi$  button, take the value of  $\pi$  to be 3.142 unless the question instructs otherwise.
- Diagrams are **NOT** accurately drawn, unless otherwise indicated.
- You must **show all your working out.**



### Information

- The total mark for this paper is 80
- The marks for **each** question are shown in brackets – *use this as a guide as to how much time to spend on each question.*

### Advice

- Read each question carefully before you start to answer it.
- Keep an eye on the time.
- Try to answer every question.
- Check your answers if you have time at the end.

Turn over ►

S48576A

©2015 Pearson Education Ltd.

6/4/17/14/6/6/6/



**PEARSON**

Answer ALL questions.

Write your answers in the spaces provided.

You must write down all the stages in your working.

- 1 The diagram shows a trapezium  $ABCD$  and two identical semicircles.

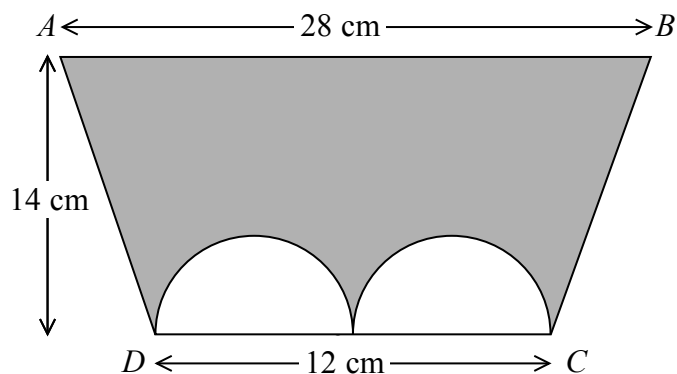

The centre of each semicircle is on  $DC$ .

Work out the area of the shaded region.

Give your answer correct to 3 significant figures.

..... cm<sup>2</sup>

(Total for Question 1 is 4 marks)

DO NOT WRITE IN THIS AREA

DO NOT WRITE IN THIS AREA

DO NOT WRITE IN THIS AREA

2 Asif is going on holiday to Turkey.

The exchange rate is  $\text{£}1 = 3.5601$  lira.

Asif changes  $\text{£}550$  to lira.

- (a) Work out how many lira he should get.  
Give your answer to the nearest lira.

..... lira  
(2)

Asif sees a pair of shoes in Turkey.  
The shoes cost 210 lira.

Asif does not have a calculator.  
He uses  $\text{£}2 = 7$  lira to work out the approximate cost of the shoes in pounds.

- (b) Use  $\text{£}2 = 7$  lira to show that the approximate cost of the shoes is  $\text{£}60$

(2)

- (c) Is using  $\text{£}2 = 7$  lira instead of using  $\text{£}1 = 3.5601$  lira a sensible start to Asif's method to work out the cost of the shoes in pounds?

You must give a reason for your answer.

.....  
.....  
(1)

**(Total for Question 2 is 5 marks)**

3 Here are the first six terms of a Fibonacci sequence.

1   1   2   3   5   8

The rule to continue a Fibonacci sequence is,

the next term in the sequence is the sum of the two previous terms.

(a) Find the 9th term of this sequence.

.....  
(1)

The first three terms of a different Fibonacci sequence are

$a$     $b$     $a + b$

(b) Show that the 6th term of this sequence is  $3a + 5b$

(2)

Given that the 3rd term is 7 and the 6th term is 29,

(c) find the value of  $a$  and the value of  $b$ .

.....  
(3)

**(Total for Question 3 is 6 marks)**



DO NOT WRITE IN THIS AREA

DO NOT WRITE IN THIS AREA

DO NOT WRITE IN THIS AREA

- 4 In a survey, the outside temperature and the number of units of electricity used for heating were recorded for ten homes.

The scatter diagram shows this information.

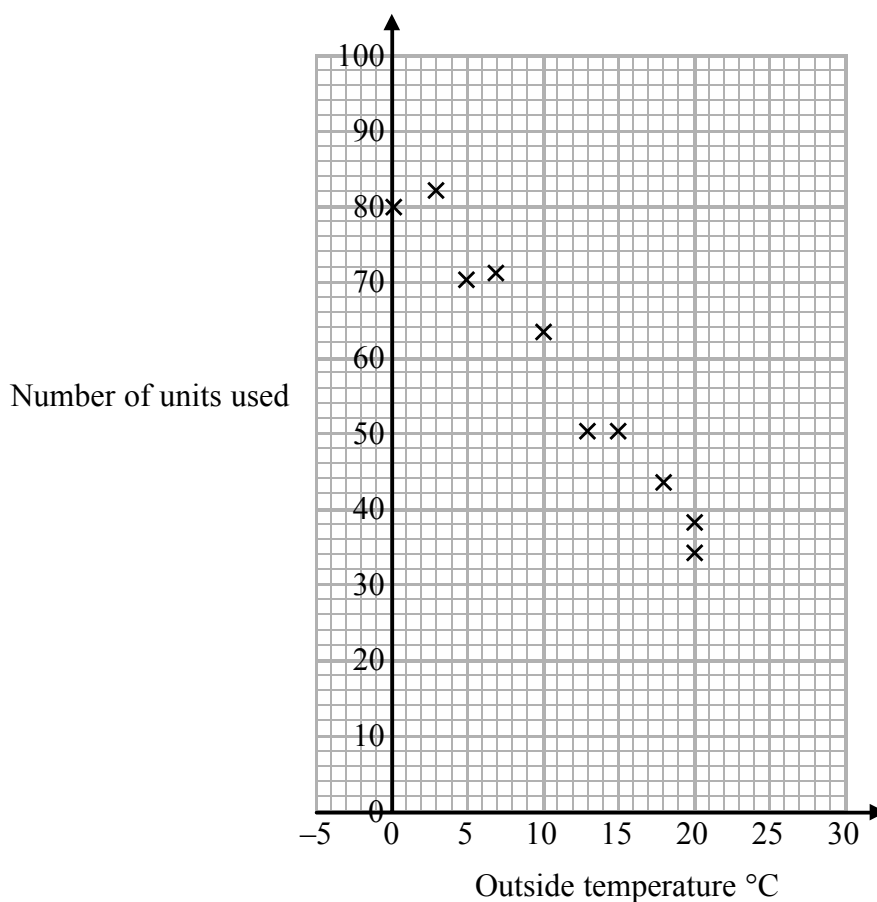

Molly says,

“On average the number of units of electricity used for heating decreases by 4 units for each °C increase in outside temperature.”

- (a) Is Molly right?  
Show how you get your answer.

(3)

- (b) You should **not** use a line of best fit to predict the number of units of electricity used for heating when the outside temperature is 30 °C.

Give one reason why.

(1)

(Total for Question 4 is 4 marks)

5 Henry is thinking of having a water meter.

These are the two ways he can pay for the water he uses.

**Water Meter**

A charge of £28.20 per year

**plus**

91.22p for every cubic metre of water used

1 cubic metre = 1000 litres

**No Water Meter**

A charge of £107 per year

Henry uses an average of 180 litres of water each day.

Use this information to determine whether or not Henry should have a water meter.

**(Total for Question 5 is 5 marks)**

DO NOT WRITE IN THIS AREA

DO NOT WRITE IN THIS AREA

DO NOT WRITE IN THIS AREA

DO NOT WRITE IN THIS AREA

DO NOT WRITE IN THIS AREA

DO NOT WRITE IN THIS AREA

6 Liz buys packets of coloured buttons.

There are 8 red buttons in each packet of red buttons.  
There are 6 silver buttons in each packet of silver buttons.  
There are 5 gold buttons in each packet of gold buttons.

Liz buys equal numbers of red buttons, silver buttons and gold buttons.

How many packets of each colour of buttons did Liz buy?

.....packets of red buttons  
.....packets of silver buttons  
.....packets of gold buttons

**(Total for Question 6 is 3 marks)**

7 The cumulative frequency table shows the marks some students got in a test.

Mark ( $m$ )	Cumulative frequency
$0 < m \leq 10$	8
$0 < m \leq 20$	23
$0 < m \leq 30$	48
$0 < m \leq 40$	65
$0 < m \leq 50$	74
$0 < m \leq 60$	80

(a) On the grid, plot a cumulative frequency graph for this information.

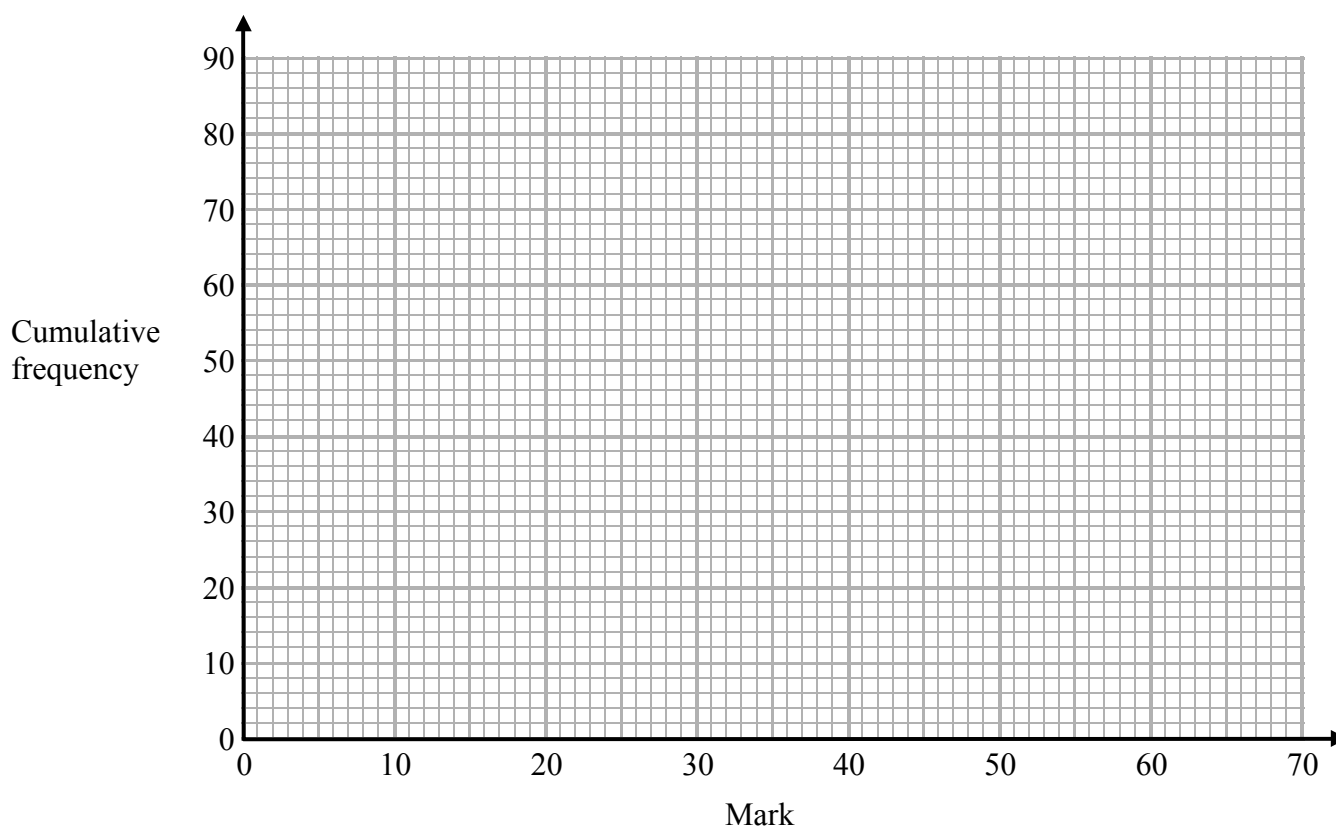

(2)

(b) Find the median mark.

(1)

Students either pass the test or fail the test.

The pass mark is set so that 3 times as many students fail the test as pass the test.

(c) Find an estimate for the lowest possible pass mark.

.....  
(3)

**(Total for Question 7 is 6 marks)**

---

**8** Write 0.000068 in standard form.

.....  
**(Total for Question 8 is 1 mark)**

---

9 (a) Factorise  $y^2 + 7y + 6$

.....  
(2)

(b) Solve  $6x + 4 > x + 17$

.....  
(2)

(c)  $n$  is an integer with  $-5 < 2n \leq 6$

Write down all the values of  $n$

.....  
(2)

**(Total for Question 9 is 6 marks)**

10 The function  $f$  is such that

$$f(x) = 4x - 1$$

(a) Find  $f^{-1}(x)$

$$f^{-1}(x) = \dots\dots\dots$$

(2)

The function  $g$  is such that

$$g(x) = kx^2 \text{ where } k \text{ is a constant.}$$

Given that  $fg(2) = 12$

(b) work out the value of  $k$

$$k = \dots\dots\dots$$

(2)

**(Total for Question 10 is 4 marks)**

11 Solve  $x^2 - 5x + 3 = 0$

Give your solutions correct to 3 significant figures.

.....  
**(Total for Question 11 is 3 marks)**

---

DO NOT WRITE IN THIS AREA

DO NOT WRITE IN THIS AREA

DO NOT WRITE IN THIS AREA

12 Sami asked 50 people which drinks they liked from tea, coffee and milk.

All 50 people like at least one of the drinks

19 people like all three drinks.

16 people like tea and coffee but do **not** like milk.

21 people like coffee and milk.

24 people like tea and milk.

40 people like coffee.

1 person likes only milk.

Sami selects at random one of the 50 people.

(a) Work out the probability that this person likes tea.

.....  
(4)

(b) Given that the person selected at random from the 50 people likes tea, find the probability that this person also likes exactly one other drink.

.....  
(2)

**(Total for Question 12 is 6 marks)**

---



DO NOT WRITE IN THIS AREA

DO NOT WRITE IN THIS AREA

DO NOT WRITE IN THIS AREA

13  $ABCD$  is a rhombus.

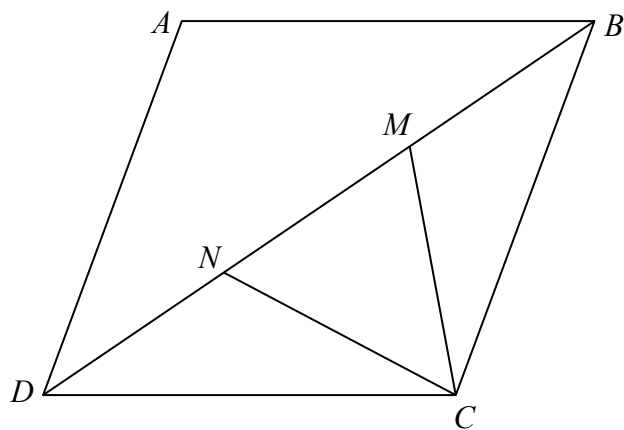

$M$  and  $N$  are points on  $BD$  such that  $DN = MB$ .

Prove that triangle  $DNC$  is congruent to triangle  $BMC$ .

(Total for Question 13 is 3 marks)

14 (a) Show that the equation  $x^3 + 4x = 1$  has a solution between  $x = 0$  and  $x = 1$

(2)

(b) Show that the equation  $x^3 + 4x = 1$  can be arranged to give  $x = \frac{1}{4} - \frac{x^3}{4}$

(1)

(c) Starting with  $x_0 = 0$ , use the iteration formula  $x_{n+1} = \frac{1}{4} - \frac{x_n^3}{4}$  twice,  
to find an estimate for the solution of  $x^3 + 4x = 1$

(3)

(Total for Question 14 is 6 marks)

DO NOT WRITE IN THIS AREA

DO NOT WRITE IN THIS AREA

DO NOT WRITE IN THIS AREA

15 There are 17 men and 26 women in a choir.  
The choir is going to sing at a concert.

One of the men and one of the women are going to be chosen to make a pair to sing the first song.

(a) Work out the number of different pairs that can be chosen.

.....  
(2)

Two of the men are to be chosen to make a pair to sing the second song.

Ben thinks the number of different pairs that can be chosen is 136

Mark thinks the number of different pairs that can be chosen is 272

(b) Who is correct, Ben or Mark?  
Give a reason for your answer.

.....  
.....  
(1)

**(Total for Question 15 is 3 marks)**

16  $VABCD$  is a solid pyramid.

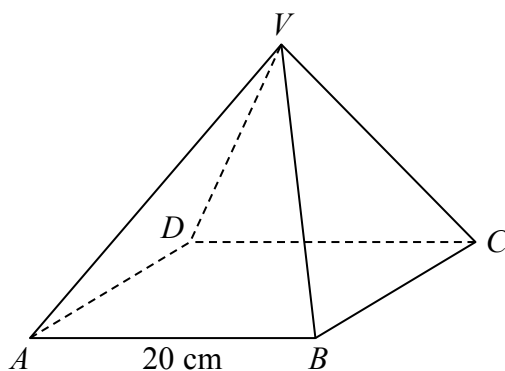

$ABCD$  is a square of side 20 cm.

The angle between any sloping edge and the plane  $ABCD$  is  $55^\circ$

Calculate the surface area of the pyramid.

Give your answer correct to 2 significant figures.

..... $\text{cm}^2$

(Total for Question 16 is 5 marks)

DO NOT WRITE IN THIS AREA

DO NOT WRITE IN THIS AREA

DO NOT WRITE IN THIS AREA

17 Louis and Robert are investigating the growth in the population of a type of bacteria. They have two flasks A and B.

At the start of day 1, there are 1000 bacteria in flask A.  
The population of bacteria grows exponentially at the rate of 50% per day.

(a) Show that the population of bacteria in flask A at the start of each day forms a geometric progression.

(2)

The population of bacteria in flask A at the start of the 10th day is  $k$  times the population of bacteria in flask A at the start of the 6th day.

(b) Find the value of  $k$ .

.....  
(2)

At the start of day 1 there are 1000 bacteria in flask B.  
The population of bacteria in flask B grows exponentially at the rate of 30% per day.

(c) Sketch a graph to compare the size of the population of bacteria in flask A and in flask B.

(1)

**(Total for Question 17 is 5 marks)**

18

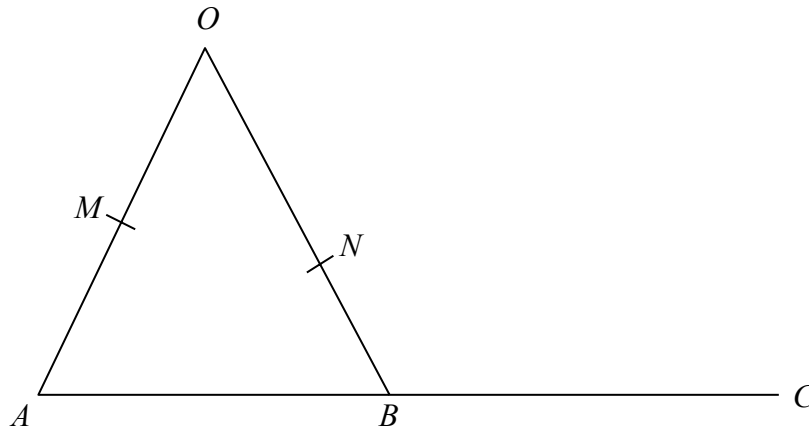

$OMA$ ,  $ONB$  and  $ABC$  are straight lines.

$M$  is the midpoint of  $OA$ .

$B$  is the midpoint of  $AC$ .

$\vec{OA} = 6\mathbf{a}$      $\vec{OB} = 6\mathbf{b}$      $\vec{ON} = k\mathbf{b}$  where  $k$  is a scalar quantity.

Given that  $MNC$  is a straight line, find the value of  $k$ .

(Total for Question 18 is 5 marks)

**TOTAL FOR PAPER IS 80 MARKS**

DO NOT WRITE IN THIS AREA

DO NOT WRITE IN THIS AREA

DO NOT WRITE IN THIS AREA

DO NOT WRITE IN THIS AREA

DO NOT WRITE IN THIS AREA

DO NOT WRITE IN THIS AREA

**BLANK PAGE**

DO NOT WRITE IN THIS AREA

DO NOT WRITE IN THIS AREA

DO NOT WRITE IN THIS AREA

**BLANK PAGE**



Paper 1MA1: 3H			
Question	Working	Answer	Notes
1		252	P1 For start to process eg. radius = $12 \div 4 (=3)$ M1 Method to find area of trapezium or semicircle or circle P1 Process to find area of the shaded region  A1 251.7 – 252
2 (a)	$550 \times 3.5601$	1958	M1 $550 \times 3.5601$ A1
(b)	$210 \div 7 \times 2 = 30 \times 2$ Or $60 \div 2 = 30$ and $30 \times 7 = 210$	Shown	M1 For correct method to convert cost in UK to lira or vice versa, using Asif's approximation C1 Shown with correct calculations
(c)		Correct evaluation	C1 For an evaluation e.g. It is a sensible start to the method because he can do the calculations without a calculator and 3.5 lira to the £ is a good approximation
3 (a)	8, 13, 21,	34	B1 cao
(b)	$a, b, a + b, a + 2b, 2a + 3b$	Shown	M1 Method to show by adding pairs of successive terms $a + 2b, 2a + 3b$ shown C1
(c)	$3a + 5b = 29$ $a + b = 7$ $3a + 3b = 21$ $b = 4, a = 3$	$a = 3$ $b = 4$	P1 Process to set up two equations P1 Process to solve equations A1

Paper 1MA1: 3H			
Question	Working	Answer	Notes
4 (a)	Draws LOBF Finds $ht \div base = \frac{85 - 20}{0 - 25} = -2.6$	No + reason	M1 Interpret question eg. draw line of best fit M1 Start to test eg. gradient e.g. $\frac{85 - 20}{0 - 25} = -2.6$ C1 Gradient within range $\pm(2 - 3)$ and 'no'
(b)		The LOBF would have to be used outside the data	C1 Convincing explanation
5		Have a water meter (from working with correct figures)	P1 Process to find number of litres eg. $180 \div 1000$ P1 Full process to find cost per day P1 Full process to find total cost of water used per year (accept use of alternative time period for both options) P1 Full process with consistent units for total cost of water A1 Correct decision from correct figures (88.13154 or correct figure for their time period)
6		15, 20, 24	P1 Process to start to find common multiple eg. prime factor decomposition of 6 and 8 or list of at least 3 multiples of all numbers P1 process to find number of packets for at least colour <b>or</b> 120 identified A1

Paper 1MA1: 3H			
Question	Working	Answer	Notes
7 (a)		11A	<p>M1 For a cumulative frequency diagram with at least 5 points plotted correctly at the ends of the intervals</p> <p>C1 For correct graph with points joined by curve or straight line segments</p> <p>[SC B1 if the shape of the graph is correct and 5 points of their points are <b>not</b> at the ends but consistently within each interval <b>and</b> joined.]</p>
(b)		26.5	B1 25 – 28
(c)	$80 \div 4 \times 3 = 60$ Draw line parallel to mark axis from CF = 50	36.5	<p>P1 For process to find number who failed eg <math>80 \div 4 \times 3 = 60</math></p> <p>P1 Draw line parallel to mark axis from CF = "60" and read off</p> <p>A1 For 35 - 38</p>
8		$6.8 \times 10^{-5}$	B1

Paper 1MA1: 3H			
Question	Working	Answer	Notes
9 (a)		$(y + 6)(y + 1)$	M1 for $(y \pm 6)(y \pm 1)$ A1
(b)	$6x - x > 17 - 4$	2.6	M1 for method to isolate terms in $x$ in an inequality or an equation A1 oe eg. $\frac{13}{5}$
(c)		-2, -1, 0, 1, 2, 3	M1 for <b>or</b> $-2.5 < n \leq 3$ <b>or</b> $-4, -2, 0, 2, 4, 6$ <b>or</b> $-4, -3, -2, -1, 0, 1, 2, 3, 4, 5, 6$ A1
10 (a)		$\frac{x + 1}{4}$	M1 start to method eg. $y = 4x - 1$ or $x = \frac{y + 1}{4}$ A1 oe
(b)		$\frac{13}{16}$	P1 for start to process eg. $f(4k) = 16k - 1$ or $g(2) = \frac{12 + 1}{4}$ A1

Paper 1MA1: 3H			
Question	Working	Answer	Notes
11	$x = \frac{- -5 \pm \sqrt{(-5)^2 - 4 \times 1 \times 3}}{2} =$ $\frac{5 \pm \sqrt{13}}{2}$	4.30 or 0.697	M1 Substitute into quadratic formula - allow sign errors M1 Evaluate as far as $\frac{5 \pm \sqrt{13}}{2}$ A1
12 (a)	Draws correct Venn diagram	$\frac{44}{50}$	M1 Begin to interpret given information e.g. 3 overlapping labelled ovals with central region correct M1 Extend interpretation of given information e.g. 3 overlapping labelled ovals with at least 5 regions correct M1 Method to communicate given information e.g. 3 overlapping labelled ovals with all regions correct including outside A1 oe
(b)		$\frac{21}{44}$	P1 For correct process to identify correct regions in Venn diagram and divide by '44' A1
13	$DN = MB$ (given) $\angle NDC = \angle MBC$ ( base angles of isosceles triangle) $DC = BC$ ( sides of a rhombus are equal) $\therefore \triangle DNC \cong \triangle BMC$ (SAS)	Proof	C1 One correct relevant statement C1 All correct relevant statements C1 Correct conclusion with reasons

Paper 1MA1: 3H			
Question	Working	Answer	Notes
14 (a)	$F(x) = x^3 + 4x - 1$ $F(0) = -1, F(1) = 4$	Shown	M1 Method to establish at least one root in $[0,1]$ e.g. $x^3 + 4x - 1$ ( $=0$ ) and $F(0) (= -1), F(1) (= 4)$ oe A1 Since there is a sign change there must be at least one root in $0 < x < 1$ (as $F$ is continuous)
(b)	$4x = 1 - x^3$ Or $\frac{x^3}{4} + x = \frac{1}{4}$	Shown	C1 C1 for at least one correct step and no incorrect ones
(c)	$x_1 = \frac{1}{4} - \frac{0}{4} = \frac{1}{4}$ $x_2 = \frac{1}{4} - \frac{\left(\frac{1}{4}\right)^3}{4} = \frac{1}{4} - \frac{1}{256}$	0.246(09375) Or $\frac{63}{256}$	B1 $x_1 = \frac{1}{4}$ M1 M1 for $x_2 = \frac{1}{4} - \frac{\left(\frac{1}{4}\right)^3}{4}$ A1 A1 for 0.246(09375) or $\frac{63}{256}$ oe
15 (a)	Number of men possible is 17 Number of women possible is 26 Each man can be paired with 26 different women $17 \times 26$	442	P1 Process to find number of combinations A1
(b)		Ben with reason	C1 Convincing reason e.g. correct calculation is $17 \times 16 \div 2$

Paper 1MA1: 3H			Notes
Question	Working	Answer	
16	$AC^2 = 20^2 + 20^2 = 800$ $AX^2 = 10^2 + 10^2 = 200$ $\sqrt{200} \times \tan 55 = VX \quad (= 20.19\dots)$ $VM^2 = \sqrt{20.19^{12} + 10^2} \quad (= 22.54\dots)$ $4 \times \frac{1}{2} \times 22.54 \times 20 + 20^2$	1300	Let $X$ be centre of base, $M$ be midpoint of $AB$ P1 process to find $AC$ or $AX$ P1 process to find $VX$ or $VA$ P1 process to find height of sloping face or angle of sloping face. P1 process to find surface area of one triangular face. A1 For 1300 – 1302
17 (a)	1000, 1500, 2250, .....	Correct Argument	M1 Method to find 1st 3 terms C1 Convincing reason e.g. common ratio is 1.5
(b)	$1000 \times 1.5^9 = k \times 1000 \times 1.5^5$ $k = \frac{1.5^9}{1.5^5}$	5.0625	P1 Process to find the value of $k$ A1
(c)		Correct sketches	C1 Draws both exponential curves intersecting on $y$ axis and clearly labelled

Paper 1MA1: 3H		Working	Answer	Notes
18	$\vec{OM} = 3\mathbf{a}$ $\vec{AB} = 6\mathbf{b} - 6\mathbf{a}$ $\vec{MC} = 3\mathbf{a} + 2(6\mathbf{b} - 6\mathbf{a})$ $= 12\mathbf{b} - 9\mathbf{a}$ $= 3(4\mathbf{b} - 3\mathbf{a})$ $\vec{MN} = k\mathbf{b} - 3\mathbf{a}$ <p><math>MNC</math> is a straight line so  <math>\vec{MC}</math> is a scalar multiple of <math>\vec{MN}</math></p>	4	<p>P1 For process to start e.g. <math>\vec{OM} = 3\mathbf{a}</math> <b>or</b>  <math>\vec{MA} = 3\mathbf{a}</math></p> <p>P1 For process to find <math>\vec{AB} (=6\mathbf{b} - 6\mathbf{a})</math></p> <p>P1 For process to find <math>\vec{MC} (=3\mathbf{a} + 2(6\mathbf{b} - 6\mathbf{a}))</math> <b>and</b>  <math>\vec{MN} (=k\mathbf{b} - 3\mathbf{a})</math></p> <p>P1 For correct process to find <math>k</math> e.g. <math>3k\mathbf{b} - 9\mathbf{a} = 12\mathbf{b} - 9\mathbf{a}</math></p> <p>A1</p>	



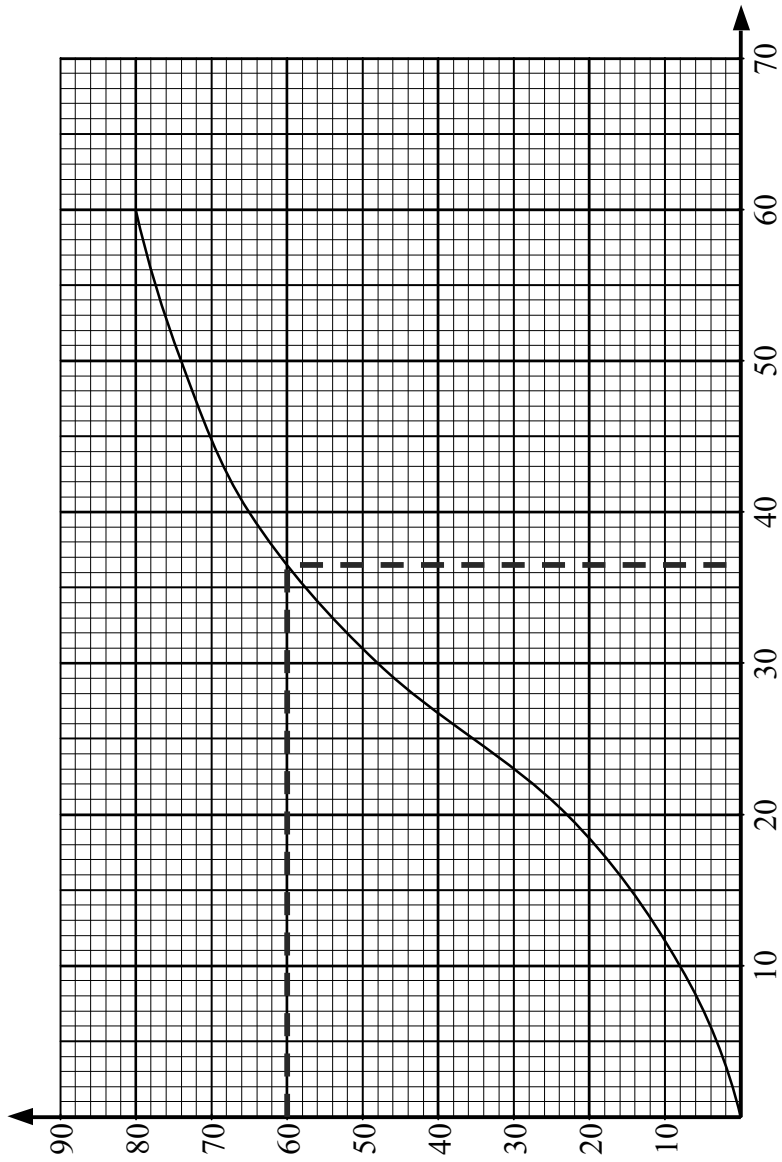

7

13

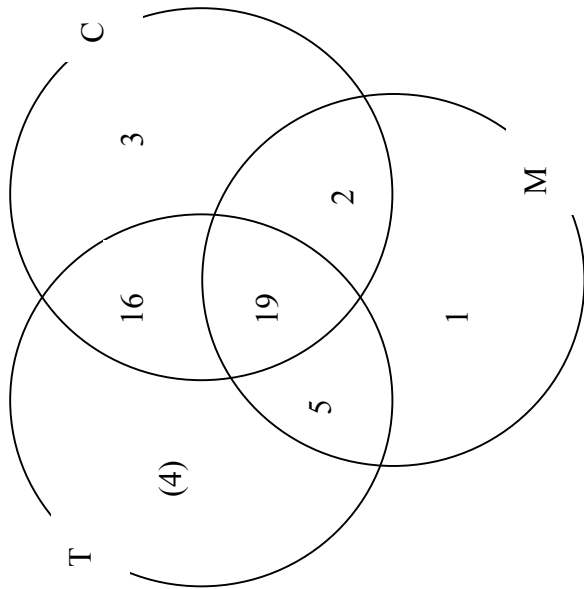

17

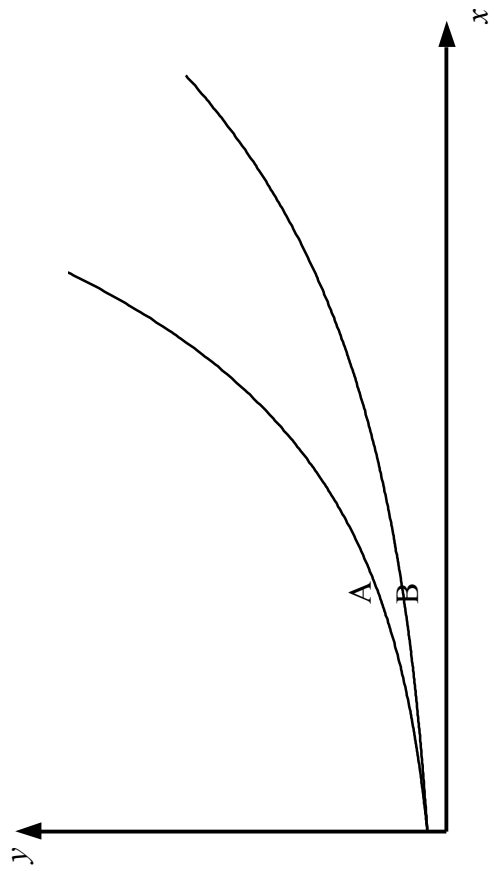

For information about Edexcel, BTEC or LCCI qualifications  
visit [qualifications.pearson.com](http://qualifications.pearson.com)

Edexcel is a registered trademark of Pearson Education Limited

Pearson Education Limited. Registered in England and Wales No. 872828  
Registered Office: 80 Strand, London WC2R 0RL  
VAT Reg No GB 278 537121